

POMPE A MANO HAND PUMPS



CARATTERISTICHE FEATURES	E-2
CARATTERISTICHE TECNICHE TECHNICAL CHARACTERISTICS	E-3
FLN 20	E-4
FPN 50	E-5
CSN12 - CSN25 - CSN45	E-6
CSIN12 - CSIN25 - CSIN45	E-8
IS6 - IS7	E-10

CARATTERISTICHE

10 Cilindrate suddivise in 4 famiglie costruttive, compongono la gamma delle pompe a mano prodotte dalla nostra società; esse trovano vastissime applicazioni nei più svariati campi della tecnologia, grazie alle loro elevate caratteristiche tecniche.

AGRICOLTURA

Sollevamento del cassone sui rimorchi ribaltabili, sollevamento a bordo di carrelli elevatori, comandi a distanza, ecc.

INDUSTRIA

Presse per montaggio, regolazione del sollevamento di piani di lavoro, estrattori oleodinamici, apertura e chiusura di auto-clavi, funzionamento di martinetti a semplice e doppio effetto, ecc.

TRASPORTI

Azionamento di piccole gru oleodinamiche a bordo di autocarri, azionamento del canale di scarico su autobetoniere, ribaltamento della cabina di autocarri, azionamenti di emergenza per autogrù in vari tipi e piattaforme aeree.

Questo genere di pompa è da considerarsi indispensabile come emergenza su qualsiasi impianto oleodinamico, specie su quelli sofisticati dove, per vari motivi venga meno il funzionamento principale, provocando di sovente intralci al traffico, con possibili conseguenze per l'incolumità delle persone.

Le nostre pompe a mano sono dotate di cursori nichelati, che permettono l'utilizzo alle massime pressioni indicate nelle corrispondenti tabelle tecniche.

Il montaggio delle pompe è possibile sia in posizione orizzontale che verticale.

FEATURES

Our factory range of hand pumps includes 4 different series featuring 10 different displacement ranges and highly advanced technical features to meet with most various applications.

FARMING & AGRICULTURE

Suitable for trailer s dump body, for lifting forks, remote controls, etc...

INDUSTRY:

Suitable for press driving, high adjustment of working tables, hydraulic strippers, surge tanks, single and double acting jacks, etc...

TRANSPORTATION

Mostly recommended for controlling small hydraulic job cranes on trucks and operation of truck mixer tailrace. Also suitable for tilting of the truck cabin and emergency drives on crane trucks and aircraft platforms.

This kind of pump is essential for all emergency operations of any hydraulic equipment (specially if high technology) when a fault of the main System occurs likely to cause traffic disturbance or danger to the operators.

Our manual pumps are equipped with nickel-plated sliders allowing for operation at the maximum pressure mentioned on relevant technical tables and can be mounted both vertically and horizontally.

CARATTERISTICHE TECNICHE

TECHNICAL CHARACTERISTICS

	FLN 20	FPN 50	CSN12 CSN25 CSN45	CSIN12 CSIN25 CSIN45	IS6 IS7
Temperatura d'esercizio <i>Working temperature</i>	-15 °C H + 80 °C				
Fluido <i>Hydraulic fluid</i>	olio minerale <i>mineral oli</i>				
Viscosità <i>Viscosity</i>	12 H + 100 mm ² /s				
Grado di filtraggio <i>Filtration rating</i>	26/23 ISO DIS 4406				
Altezza max. d' aspirazione <i>Max. suction height</i>	700 mm				



FLN 20 E-4



FPN 50 E-5



CSN... E-6

CSIN... E-8

IS... E-10



FLN 20

POMPA A MANO A DOPPIO EFFETTO DOUBLE ACTING MANUAL PUMP

Dimensioni / Dimensions

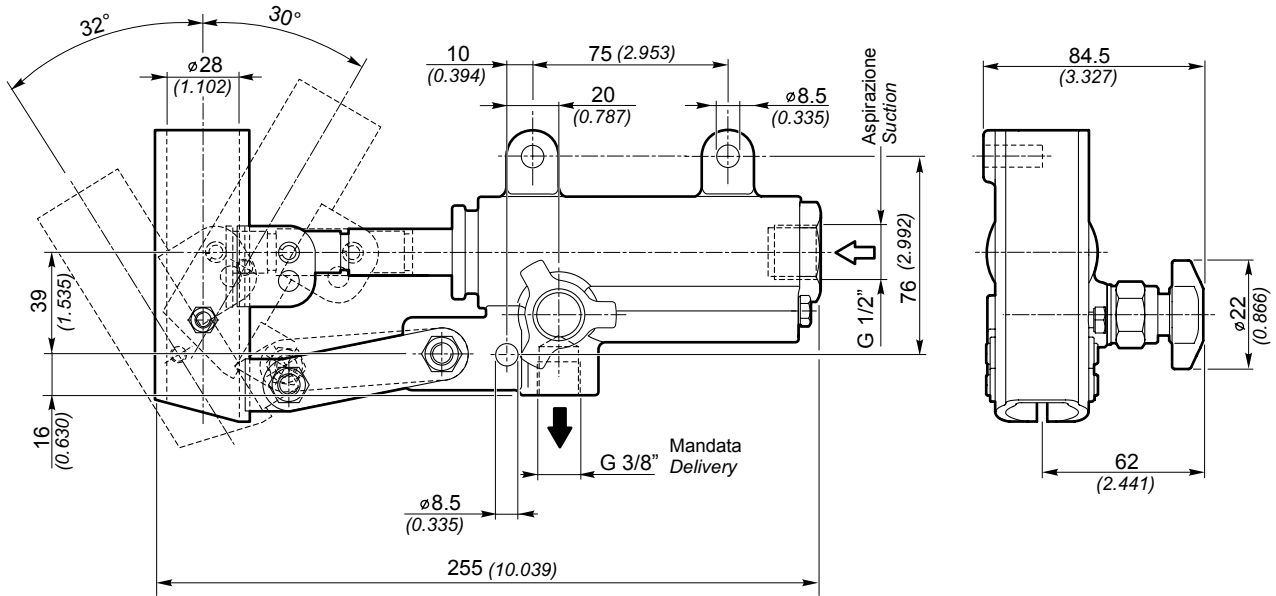
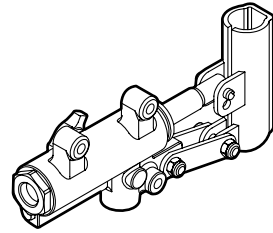
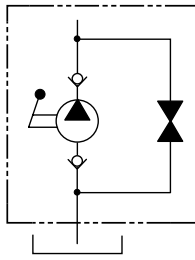

Dati tecnici / Technical data

Grandezza Size	Cilindrata Displacement [cm ³ /rev] [in ³ /rev]	Pressione max. Max. pressure [bar] [PSI]	Forza* Force* [daN] [lbs]	Massa Mass [Kg] [lbs]
FLN 20	20 (1.22)	350 (4060)	60 (135)	2.6 (5.73)

* Forza con 1000 mm di leva alla pressione max. di lavoro
 * Stress with 39.37 inch long lever at max. working pressure

Esempio di ordinazione in codice / Example of ordering code

FLN 20 0

FLN 20	Tipo / Type	vedi tabella / see table
0	Pompa / Pump	0 = Pompa senza leva / Pump without lever 1 = Pompa con leva (l=610mm) / Pump with lever (l=610 mm)

FPN 50

POMPA A MANO A DOPPIO EFFETTO DOUBLE ACTING MANUAL PUMP

Dimensioni / Dimensions

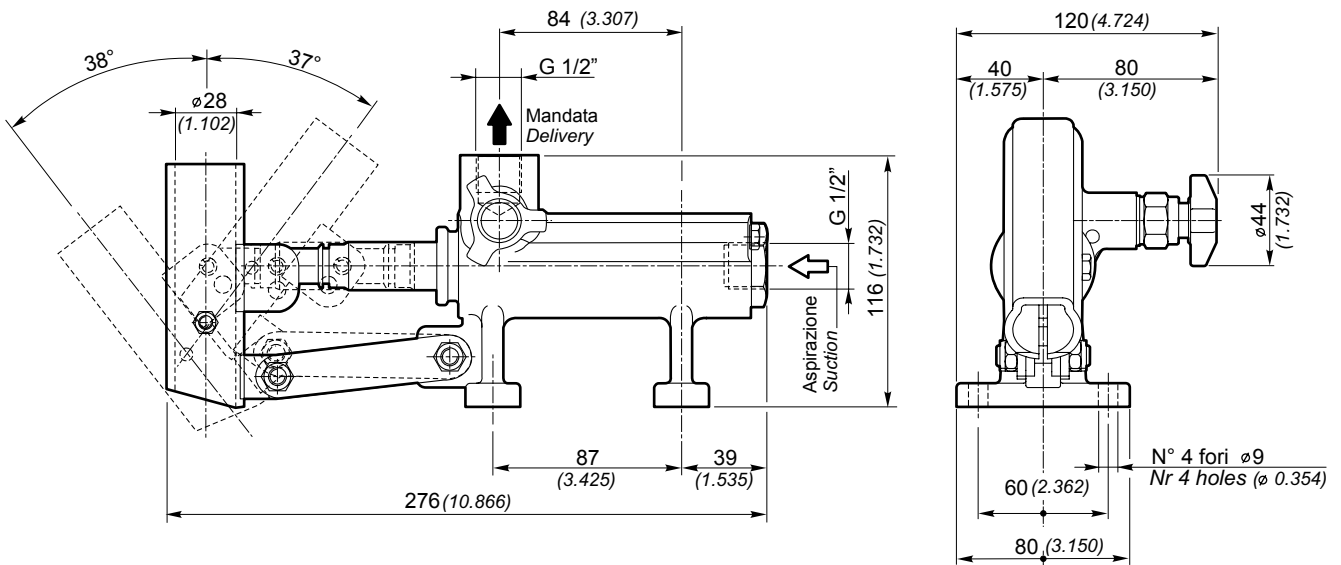
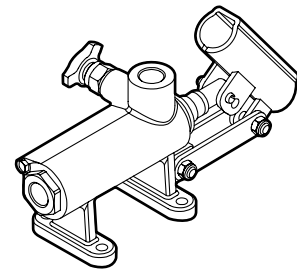
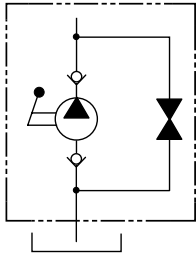

Dati tecnici / Technical data

Grandezza Size	Cilindrata Displacement [cm ³ /rev] [in ³ /rev]	Pressione max. Max. pressure [bar] [PSI]	Forza* Force* [daN] [lbs]	Massa Mass [Kg] [lbs]
FPN 50	44 (2.68)	280 (4060)	91.8 (206)	3.4 (7.50)

* Sforzo con leva di 600 mm alla pressione max. di lavoro
* Working effort with 23.622 inch lever to the max. pressure of work

Esempio di ordinazione in codice / Example of ordering code

FPN 50 | **0**

FPN 50	Tipo / Type	vedi tabella / see table
0	Pompa / Pump	0 = Pompa senza leva / Pump without lever 1 = Pompa con leva (l=610mm) / Pump with lever (l=610 mm)

CSN12 - CSN25 - CSN45

POMPA A MANO A DOPPIO EFFETTO DOUBLE ACTING MANUAL PUMP

Dimensioni / Dimensions

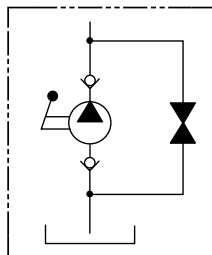
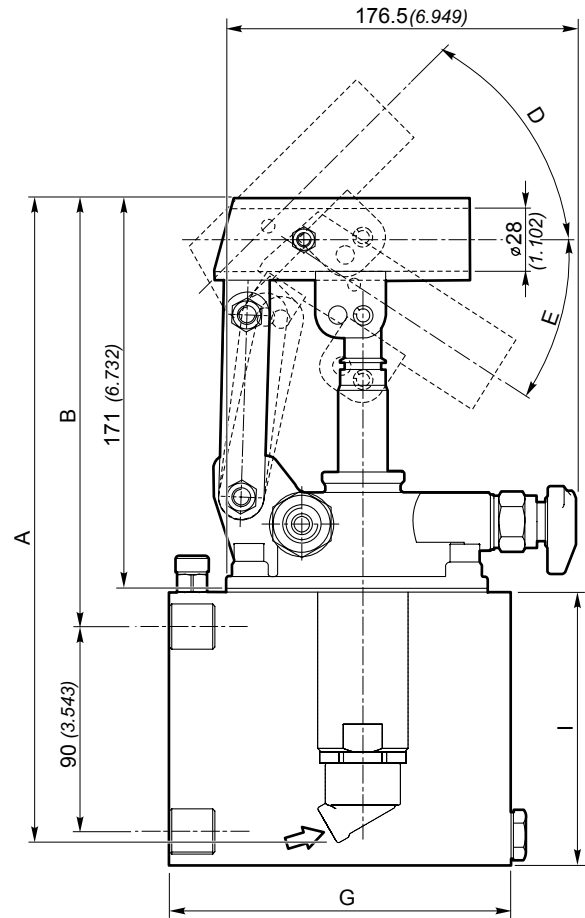
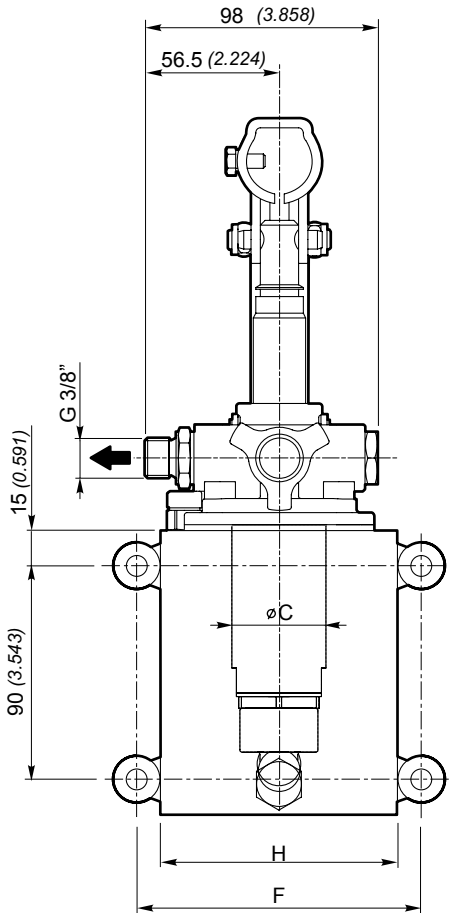
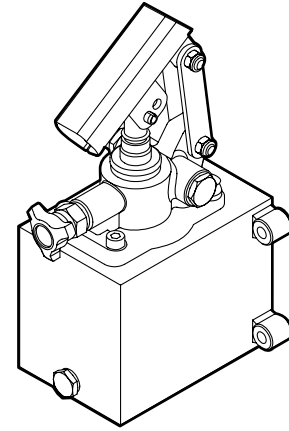
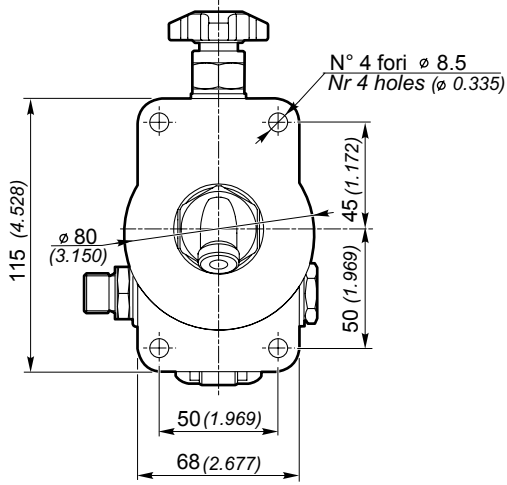

CSN12 - CSN25 - CSN45

POMPA A MANO A DOPPIO EFFETTO DOUBLE ACTING MANUAL PUMP

Dati tecnici / Technical data

Pompa / Pump

Grandezza Size	Cilindrata Displacement [cm ³ /rev] (in ³ /rev)	Pressione max. Max. pressure [bar] (PSI)	Forza* Force* [daN] (lbs)	Dimensioni Dimensions					Massa pompa senza serbatoio Mass of pump without [Kg] (lbs)
				A [mm] (inch)	B [mm] (inch)	C [mm] (inch)	D [mm] (inch)	E [mm] (inch)	
CSN 12	12 (0.73)	380 (5510)	46 103	253 (9.961)	166 (6.535)	34 (1.339)	26 (1.024)	31 (1.220)	3.0 (6.62)
CSN 25	25 (1.53)	350 (5075)	77 (173)	273 (10.748)	172 (6.772)	34 (1.339)	30 (1.181)	30 (1.181)	
CSN 45	45 (2.75)	280 (4060)	93 (209)	283 (11.142)	172 (6.772)	40 (1.575)	45 (1.772)	33 (1.299)	

* Sforzo con leva di 600 mm alla pressione max. di lavoro

* Working effort with 23.622 inch lever to the max. pressure of work

Serbatoio / Tank

Capacità Serbatoio Tank capacity [l] (US Gal)	Dimensioni Dimensions				Massa serbatoio Mass of tank [Kg] (lbs)
	F [mm] (inch)	G [mm] (inch)	H [mm] (inch)	I [mm] (inch)	
1 (0.26)	120 (4.724)	150 (5.906)	100 (3.937)	120 (4.724)	2.2 (4.85)
2 (0.53)				185 (7.283)	3.0 (6.62)
3 (0.79)				255 (10.039)	3.7 (8.16)
5 (1.32)	195 (7.677)	175 (6.890)	175 (6.890)	200 (7.874)	5.3 (11.69)
7 (1.85)				275 (10.827)	6.6 (14.55)
10 (2.64)				380 (14.961)	8.3 (18.30)

Esempio di ordinazione in codice / Example of ordering code

CSN 12 | **4** | **(150)** | **1** | **0**

CSN 12	Tipo / Type	vedi tabella / see table
4	Opzioni / Options	0 = Senza optional / Without optionals 4 = Valvola limitatrice di pressione / Pressure relief valve
(150)	Taratura VLP in bar (da omettere se non è richiesta la VLP) Relief valve setting bar (to leave out in case is not required relief valve)	
1	Serbatoio Tank	0 = Pompa fornita senza serbatoio / Pump without tank 1 = Pompa fornita con serbatoio capacità 1 lt / Pump with tank capacity 1 lt 2 = Pompa fornita con serbatoio capacità 2 lt / Pump with tank capacity 2 lt 3 = Pompa fornita con serbatoio capacità 3 lt / Pump with tank capacity 3 lt 5 = Pompa fornita con serbatoio capacità 5 lt / Pump with tank capacity 5 lt 7 = Pompa fornita con serbatoio capacità 7 lt / Pump with tank capacity 7 lt 10 = Pompa fornita con serbatoio capacità 10 lt / Pump with tank capacity 10 lt
0	Leva Lever	0 = Pompa senza leva / Pump without lever 1 = Pompa con leva (l=610mm) / Pump with lever (l=610 mm)

CSIN12 - CSIN25 - CSIN45

POMPA A MANO A DOPPIO EFFETTO DOUBLE ACTING MANUAL PUMP

Dimensioni / Dimensions

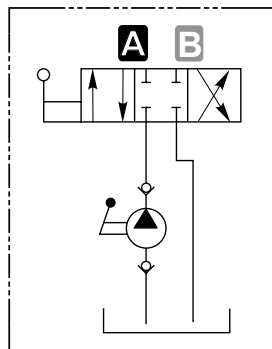
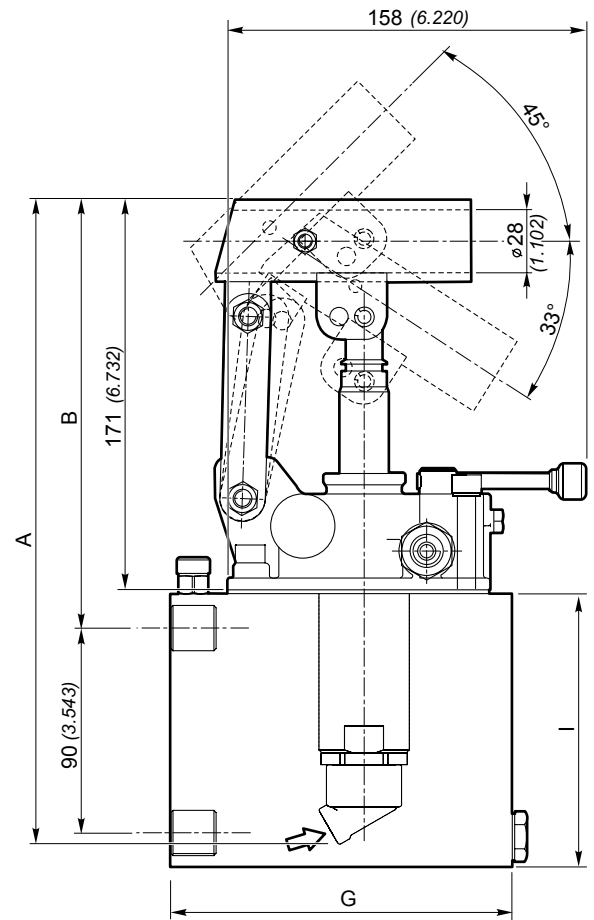
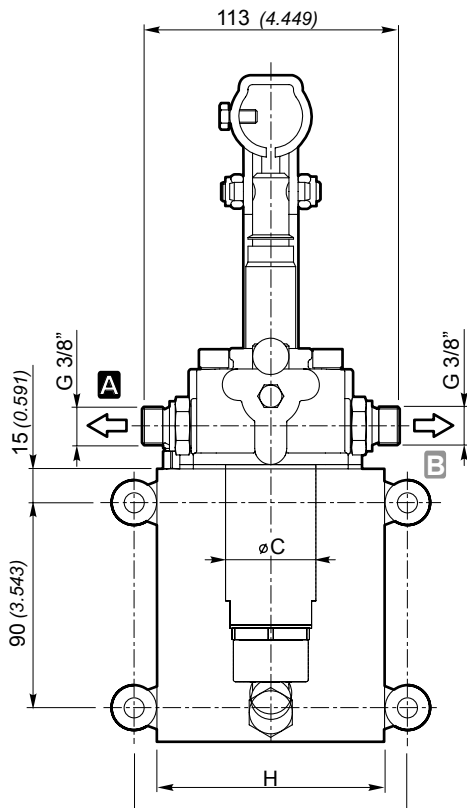
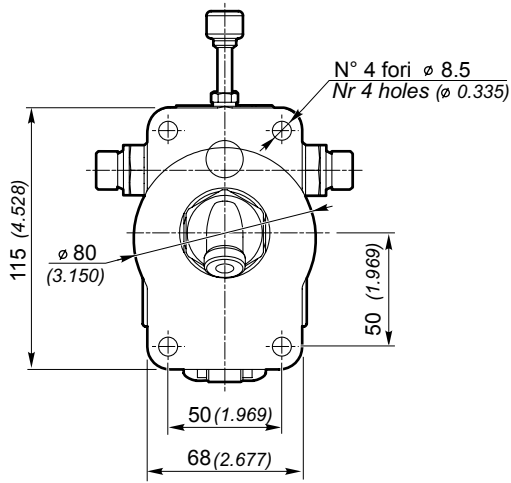
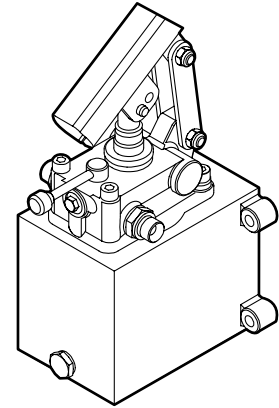

CSIN12 - CSIN25 - CSIN45

POMPA A MANO A DOPPIO EFFETTO DOUBLE ACTING MANUAL PUMP

Dati tecnici / Technical data

Pompa / Pump

Grandezza Size	Cilindrata Displacement [cm ³ /rev] (in ³ /rev)	Pressione max. Max. pressure [bar] (PSI)	Forza* Force* [daN] (lbs)	Dimensioni Dimensions					Massa pompa senza serbatoio Mass of pump without [Kg] (lbs)
				A [mm] (inch)	B [mm] (inch)	C [mm] (inch)	D [mm] (inch)	E [mm] (inch)	
CSIN 12	12 (0.73)	380 (5510)	46 103	253 (9.961)	166 (6.535)	34 (1.339)	26 (1.024)	31 (1.220)	3.5 (7.72)
CSIN 25	25 (1.53)	350 (5075)	77 (173)	273 (10.748)	172 (6.772)	34 (1.339)	30 (1.181)	30 (1.181)	
CSIN 45	45 (2.75)	280 (4060)	93 (209)	283 (11.142)	172 (6.772)	40 (1.575)	45 (1.772)	33 (1.299)	

* Sforzo con leva di 600 mm alla pressione max. di lavoro

* Working effort with 23.622 inch lever to the max. pressure of work

Serbatoio / Tank

Capacità Serbatoio Tank capacity [l] (US Gal)	Dimensioni Dimensions				Massa serbatoio Mass of tank [Kg] (lbs)
	F [mm] (inch)	G [mm] (inch)	H [mm] (inch)	I [mm] (inch)	
1 (0.26)	120 (4.724)	150 (5.906)	100 (3.937)	120 (4.724)	2.2 (4.85)
2 (0.53)				185 (7.283)	3.0 (6.62)
3 (0.79)				255 (10.039)	3.7 (8.16)
5 (1.32)	195 (7.677)	175 (6.890)	175 (6.890)	200 (7.874)	5.3 (11.69)
7 (1.85)				275 (10.827)	6.6 (14.55)
10 (2.64)				380 (14.961)	8.3 (18.30)

Esempio di ordinazione in codice / Example of ordering code

CSIN 12 | **4** | **(150)** | **1** | **0**

CSIN 12	Tipo / Type	vedi tabella / see table
4	Opzioni / Options	0 = Senza optional / Without optional 4 = Valvola limitatrice di pressione / Pressure relief valve
(150)	Taratura VLP in bar (da omettere se non è richiesta la VLP) Relief valve setting bar (to leave out in case is not required relief valve)	
1	Serbatoio Tank	0 = Pompa fornita senza serbatoio / Pump without tank 1 = Pompa fornita con serbatoio capacità 1 lt / Pump with tank capacity 1 lt 2 = Pompa fornita con serbatoio capacità 2 lt / Pump with tank capacity 2 lt 3 = Pompa fornita con serbatoio capacità 3 lt / Pump with tank capacity 3 lt 5 = Pompa fornita con serbatoio capacità 5 lt / Pump with tank capacity 5 lt 7 = Pompa fornita con serbatoio capacità 7 lt / Pump with tank capacity 7 lt 10 = Pompa fornita con serbatoio capacità 10 lt / Pump with tank capacity 10 lt
0	Leva Lever	0 = Pompa senza leva / Pump without lever 1 = Pompa con leva (l=610mm) / Pump with lever (l=610 mm)

IS6 - IS7

POMPA A MANO A DOPPIO EFFETTO DOUBLE ACTING MANUAL PUMP

Dimensioni / Dimensions

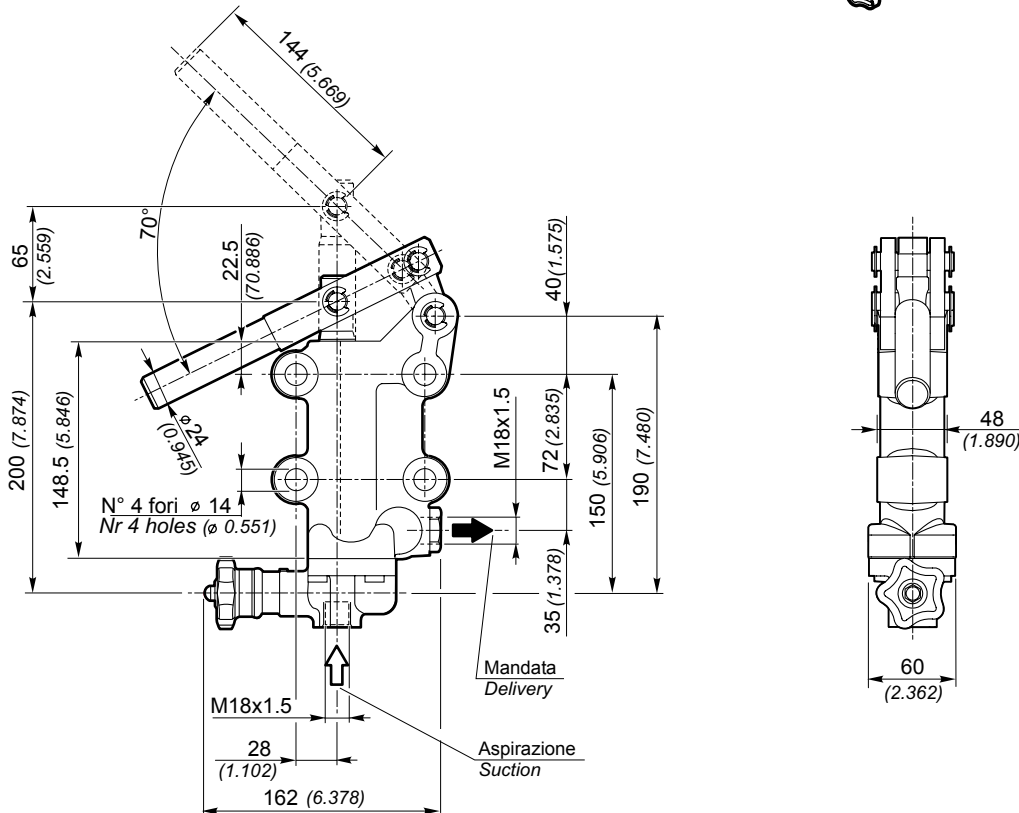
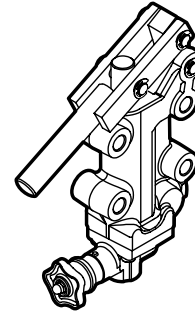
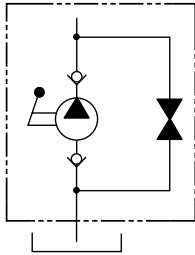

Dati tecnici / Technical data

Grandezza Size	Cilindrata Displacement [cm ³ /rev] [in ³ /rev]	Ø Pistone Ø Pistone [mm] [inch]	Pressione max. Max. pressure [bar] [PSI]	Forza* Force* [daN] [lbs]	Massa Mass [Kg] [lbs]
IS6	20 (1.22)	20 (0.787)	250 (3625)	50 (112)	5.6 (12.35)
IS7	30 (1.83)	25 (0.984)	200 (2900)	65 (146)	5.6 (12.35)

* Sforzo con leva di 1000 mm alla pressione max. di lavoro
* Working effort with 39.37 inch lever to the max. pressure of work

Esempio di ordinazione in codice / Example of ordering code

IS6

IS6	Tipo / Type	vedi tabella / see table
------------	-------------	--------------------------