

1.0 INDICE
1.0 INDEX
1.0 INHALTSVERZEICHNIS

	Pag.		Page		Seite
2.0 CARATTERISTICHE GENERALI		2.0 GENERAL CHARACTERISTICS		2.0 ALLGEMEINE MERKMALE	
2.1 Tipi e versioni	2	2.1 <i>Types and versions</i>	2	2.1 Typen und Versionen	2
2.2 Designazione	2	2.2 <i>Designation</i>	2	2.2 Bezeichnung	2
3.0 CARATTERISTICHE MECCANICHE		3.0 MECHANICAL CHARACTERISTICS		3.0 MECHANISCHE MERKMALE	
3.1 Forma costruttiva	3	3.1 <i>Mounting positions</i>	3	3.1 Bauform	3
3.2 Protezioni	3	3.2 <i>Protection</i>	3	3.2 Schutzart	3
3.3 Scatola morsettiera	3	3.3 <i>Terminal box</i>	3	3.3 Klemmenkasten	3
3.4 Carichi radiali e assiali	3	3.4 <i>Radial and axial loads</i>	3	3.4 Radial und Axialbelastungen	3
4.0 CARATTERISTICHE ELETTRICHE MOTORI TRIFASE		4.0 ELECTRICAL CHARACTERISTICS THREEPHASE MOTORS		4.0 ELEKTRISCHE MERKMALE DREHSTROMMOTOREN	
4.1 Potenza	4	4.1 <i>Power</i>	4	4.1 Leistung	4
4.2 Tensione e frequenza	4	4.2 <i>Frequency and tension</i>	4	4.2 Spannung und Frequenz	4
4.3 Classe di isolamento	4	4.3 <i>Insulation class</i>	4	4.3 Isolationsklasse	4
4.4 Schemi di collegamento motori trifase	4	4.4 <i>Threephase motor wiring diagram</i>	4	4.4 Anschlußpläne für Drehstrommotoren	4
5.0 CARATTERISTICHE ELETTRICHE MOTORI MONOFASE		5.0 ELECTRICAL CHARACTERISTICS SINGLE PHASE MOTORS		5.0 ELEKTRISCHE MERKMALE EINPHASENMOTOREN	
5.1 Generalità	5	5.1 <i>General</i>	5	5.1 Allgemeines	5
5.2 Alta coppia di spunto	5	5.2 <i>High starting torque</i>	5	5.2 Hohes Anlaufmoment	5
5.3 Classe di isolamento e protezione	5	5.3 <i>Insulation class and protection</i>	5	5.3 Isolationsklasse und Schutzart	5
5.4 Senso di rotazione	5	5.4 <i>Direction of rotation</i>	5	5.4 Drehrichtung	5
5.5 Avvolgimento simmetrico	5	5.5 <i>Symmetrical winding</i>	5	5.5 Symmetrische Wicklung	5
5.6 Schemi di collegamento motori monofase	5	5.6 <i>Single phase motor wiring diagram</i>	5	5.6 Schaltungsplan für Einphasenmotoren	5
6.0 MOTORI AUTOFRENANTI		6.0 BRAKE MOTORS		6.0 BREMSMOTOREN	
6.1 Generalità	6	6.1 <i>General</i>	6	6.1 Allgemeines	6
6.2 Protezione e isolamento	6	6.2 <i>Protection and insulation</i>	6	6.2 Schutzart und Isolation	6
6.3 Leva di sblocco	6	6.3 <i>Hand release</i>	6	6.3 Handlüftung	6
7.0 FRENO A C.A.		7.0 A.C. BRAKE		7.0 Ws - BREMSE	
7.1 Caratteristiche tecniche del freno a c.a.	7	7.1 <i>A.C. brake technical characteristics</i>	7	7.1 Technische Merkmale der Ws-Bremse	7
8.0 FRENO A C.C.		8.0 D.C. BRAKE		8.0 Gs-BREMSE	
8.1 Caratteristiche tecniche del freno a c.c.	8	8.1 <i>D.C. brake technical characteristics</i>	8	8.1 Technische Merkmale der Gs-Bremse	8
8.2 Raddrizzatori di corrente	9	8.2 <i>Current rectifiers</i>	9	8.2 Gleichrichter	9
9.0 VERIFICHE E REGOLAZIONI	10	9.0 CHECKS AND ADJUSTMENTS	10	9.0 KONTROLLEN UND EINSTELLUNGEN	10
10.0 OPZIONI A RICHIESTA	12	10.0 OPTIONS UPON REQUEST	12	10.0 OPTIONAL AUF ANFRAGE	12
11.0 DATI TECNICI	14	11.0 TECHNICAL DATA	14	11.0 TECHNISCHE DATEN	14
12.0 DIMENSIONI	21	12.0 DIMENSIONS	21	12.0 ABMESSUNGEN	21
13.0 FRENO A C.C. SERIE FS	24	13.0 D.C. BRAKE FS SERIES	24	13.0 Gs - BREMSE SERIE FS	24
14.0 FRENO A C.A. SERIE FP	26	14.0 A.C. BRAKE FP SERIES	26	14.0 Ws - BREMSE SERIE FP	26
14.1 Caratteristiche tecniche del freno a c.a.		14.1 <i>A.C. brake technical characteristics</i>		14.1 Technische Merkmale der Ws-Bremse	
14.2 Dimensioni serie FP		14.2 <i>Dimensions FP series</i>		14.2 Abmessungen serie FP	
14.3 Verifiche e Regolazioni		14.3 <i>Checks and Adjustments</i>		14.3 Kontrollen und Einstellungen	
15.0 PARTI DI RICAMBIO TN-TF	29	15.0 SPARE PARTS TN-TF	29	15.0 ERSATZTEILE TN-TF	29
16.0 PARTI DI RICAMBIO FP	30	16.0 SPARE PARTS FP	30	16.0 ERSATZTEILE FP	30

N.B. I dati del presente catalogo sono indicativi e non impegnativi; e sono suscettibili di modifiche senza preavviso.

N.B. The data contained in this catalogue are indicative and not mandatory and can be modify without prior notice.

N.B. Die in diesem Katalog angegebenen Daten sind Richtwerte und nicht verbindlich. Un angekündigte Änderungen sind möglich.

2.0 CARATTERISTICHE GENERALI

2.0 GENERAL CHARACTERISTICS

2.0 ALLGEMEINE MERKMALE

2.1 Tipi e versioni

I motori MT a corrente alternata sono previsti nelle seguenti versioni:

	TN
	DN
	MN
	XN
	TF
	DF
	MF
	XF
	FP-DFP
	FS-DFS

2.1 Types and versions

MT a.c. motors are supplied in the following versions:

TN	Trifase standard / Standard Threephase Motor / Standard Drehstrommotor
DN	Trifase, polarità doppia / Threephase, double speed / Polumschaltbaremotoren
MN	Monofase standard / Standard Single phase motor / Standard Einphasenstrommotor
XN	Monofase con alta coppia di spunto / Single phase motor with high starting torque / Einphasenstrommotor mit hoes Anlaufmoment
TF	Trifase autofrenante standard / Standard Threephase brake motor / Standard Drehstrommotor mit Bremse
DF	Trifase autofrenante, polarità doppia / Threephase brake motor, double speed / Doppelpoliger Drehstrommotor
MF	Monofase autofrenante standard / Standard single phase brake motor / Einphasen Bremsmotor
XF	Monofase autofrenante con alta coppia di spunto / Single phase brake motor with high starting torque / Einphasen Bremsmotor mit hoes Anlaufmoment
FP-DFP	Elevato momento frenante, alta velocità di intervento freno / High braking torque, quick intervention / Hoes Bremsmoment, Schneller Eingriff
FS-DFS	Freno di stazionamento / Standing brake / Stahenden Bremse

2.1 Typen und Versionen

MT-Wechselstrommotoren gibt es in folgenden Versionen:

L'intera gamma attuale, dalla grandezza 55 alla 200, utilizza carcasse e coperchi in alluminio pressofuso, ventole esterne bidirezionali costruite in materiale plastico e calotte copriventola in lamiera d'acciaio. Tutte le caratteristiche dimensionali e costruttive dei motori MT sono conformi alle norme IEC, UNEL, CEI.

In the whole range, from size 55 to 200, housings and covers are made of die-cast aluminium, the external bidirectional fans are made of plastic material and the fan covers in steel sheets. The dimensional and constructive characteristics of MT motors conform to IEC, UNEL, CEI specifications.

Alle Modelle der derzeitigen Motorenpalette, von Baugröße 55 bis 200, haben Gehäuse und Deckel aus Alu-Druckguß, Richtungsventilatoren an der Außenseite aus Kunststoff und Lüfterhauben aus Stahlblech. Maße und Konstruktionsmerkmale der MT-Motoren entsprechen den Anforderungen der IEC, UNEL und CEI-Normen.

2.2 Designazione

Tipo Type Typ	Grand. Size Größe	Potenza Power Leistung	N. poli N. poles Polzahl	Tensione Voltage Spannung	Frequenza Frequency Frequenz	Protezione Protection Schutzart	Isolament onsluation Isolation	Forma costruttiva Mounting positions Bauform
TN	63	0.18	4	230/400	50	IP55	CL F	B5
TN DN MN XN TF DF MF XF FP DFP FS DFS	55 ÷ 355	Kw (HP)	2 4 6 8 2/4 4/6 4/8 2/6 2/8 6/8	230-400V standard trifase threephase Drehstrom 230V standard monofase singlephase Einphasen	50 Hz standard 60 Hz a richiesta on request auf Anfrage	(pag.3) (page 3) (seite 3)	CL F standard CL H a richiesta on request auf Anfrage	B5 B14 B3 pos.1 standard B3L pos.2 B3L pos.3 B3/B5 B3/B14 a rich. / on request auf Anfrage

2.2 Designation

2.2 Bezeichnung

ALTRE SPECIFICHE OTHER SPECIFICATIONS WEITERE SPEZIFIKATION	
TN-DN-MN XN-TF-DF MF-XF	Albero bisporgente Double extended output shaft Beidseitig vorstehende Welle
XN XF	Condensatore di avviamento Starting Capacitor Anlaufkondensator
TF DF	Freno c.a. (standard per trifase) A.C. brake (standard on threephase) Ws-Bremse (Standard für Drehstrommotor)
TF MF DF	Freno c.c. (standard per monofase) D.C. brake (standard on single phase) Gs-Bremse (Standard für Einphasenmotor)
TF MF DF	Scheda frenatura rapida (per freno c.c.) Fast braking card (on D.C. brake) Schnellbrems-Karte (für Gs-Bremse)
TF MF DF	Leva di sblocco Hand release Handlüftung
tutti/all/alle	Tropicalizzazione Tropicalization Tropenschutz Albero ridotto Reduced shaft Kleinwelle Flangia ridotta Reduced flange Kleinflansch

FLANGE RIDOTTE E MAGGIORATE DISPONIBILI REDUCED FLANGES AVAILABLE LIEFERBARE KLEINFLANSCH

Tipo motore Motor type Motor typ	Tipo flangia / Flange type / Flanschtyp		
	B14 ridotta Reduced flanged Verkleinerter	B14 maggiorata Oversize Überdimensionierter	B5 ridotta Reduced flanged Verkleinerter
56	—	63 B14	—
63	56 B14	71 - 80 B14	—
71	63 B14	80 - 90 B14	63 B5
80	71 B14	90 - 100 B14	71 B5
90	80 B14	100 B14	71 B5
100	80/90 B14	132 B14	90 B5
112	90 B14	—	90 B5
132	—	—	112 B5

3.0 CARATTERISTICHE MECCANICHE

3.0 MECHANICAL CHARACTERISTICS

3.0 MECHANISCHE MERKMALE

3.1 Forma costruttiva

Tutti i motori sono previsti nelle seguenti forme costruttive:

3.1 Construction form

All motors are supplied in the following types:

3.1 Bauform

Alle Motoren sind in folgenden Bauformen erhältlich:

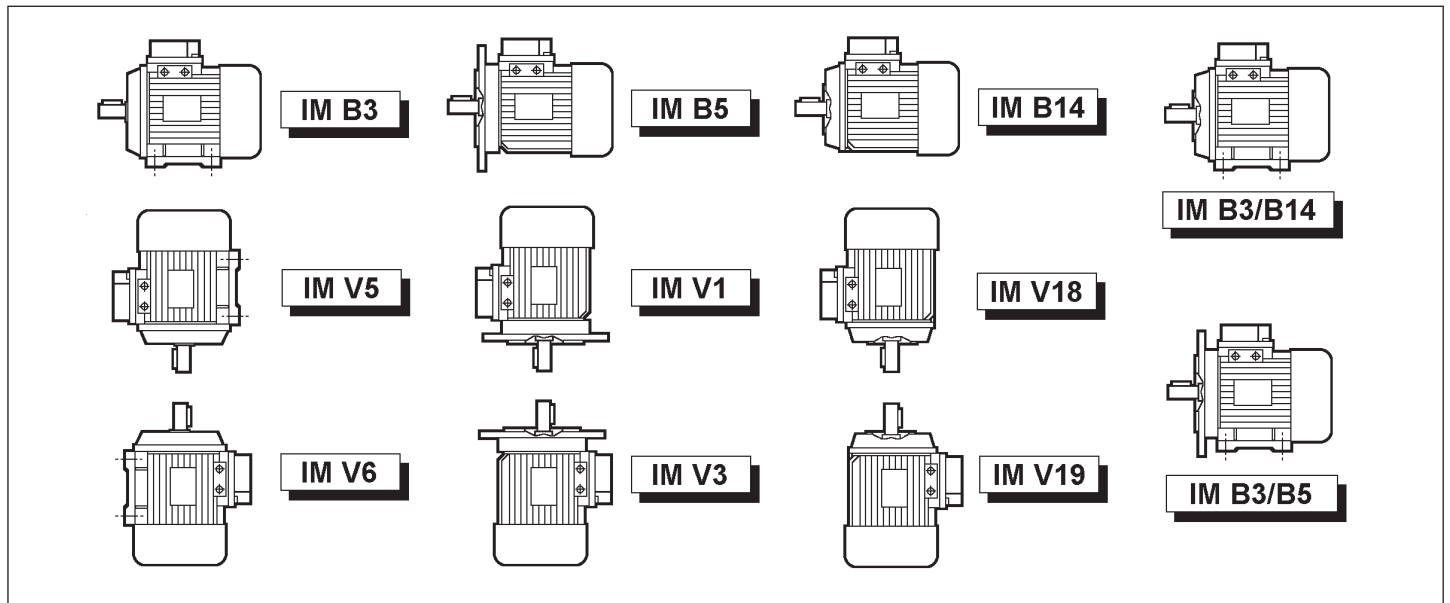

3.2 Protezioni

3.2 Protection

3.2 Schutzarten

TN - DN MN - XN	Protezione/Protection/Schutzart		TF - DF MF - XF FP - FS	Protezione/Protection/Schutzart	
	Standard	A richiesta on request auf anfrage		Standard	A richiesta on request auf anfrage
55 - 132	IP55	IP65	56 - 200	IP54	IP55, IP65
160 - 280	IP54	IP55			
315 - 355	IP44	IP54, IP55			

3.3 Scatola morsettiera

Nelle forme costruttive con piede la scatola morsettiera può essere orientata in tre posizioni. Essa è posta normalmente in alto (1); a richiesta può essere collocata a destra (3) o, tramite esecuzione speciale, a sinistra (2).

Nei motori a polarità singola o doppia contiene 6 morsetti (a richiesta 12).

3.3 Terminal box

In the foot mounted types, the terminal box can be located in three different positions. On the standard type it is located on the top (1), upon request it can be located on the right (3) or on the left hand side.

Standard and double speed motors are equipped with a six terminals board (12 upon request).

3.3 Klemmenkasten

In der Bauform mit Fuß gibt es für die Klemmenkasten drei Positionsmöglichkeiten. Normalerweise befindet sie sich oben (1). Sie kann aber auf Anfrage auch rechts (3) oder in Sonderausführung links platziert werden.

Bei ein oder doppelpoligen Motoren enthält die Klemmbrett 6 Klemmen (auf Anfrage 12).

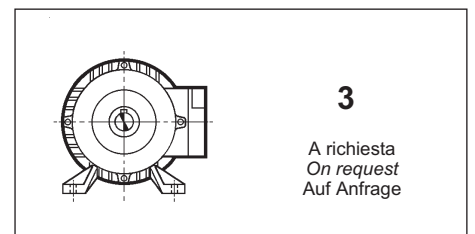
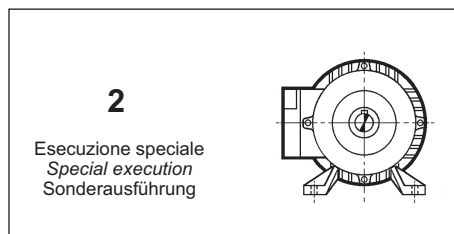
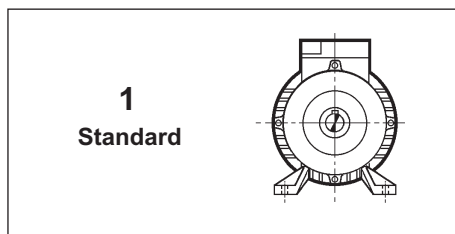

3.4 Carichi radiali e assiali

La tabella sottostante riporta i massimi carichi radiali (N) ammissibili sulla mezzeria della sporgenza dell'albero motore e relativi carichi assiali.

3.4 Radial and axial loads

The table underneath lists the maximum radial loads (N) allowable on the centerline of the shaft extension and the relevant axial loads.

3.4 Radial und Axialbelastungen

In der nachstehenden Tabelle sind die max. zulässigen Radialelastungen (N) auf die Mitte des Wellenüberstands angegeben und relativen Axialbelastungen.

Rpm	Grandezza motore / Motor size / Motorbaugröße																							
	55		56		63		71		80		90		100		112		132		160		180		200	
3000	240	100	240	100	300	120	470	190	600	250	650	330	1000	470	1300	600	2000	1000	2500	1200	3000	1500	4200	1900
1500	310	140	310	140	360	160	530	250	700	330	850	450	1200	630	1600	800	2500	1300	3100	1700	4000	2000	5300	2500
1000	350	170	350	170	370	200	550	310	750	400	950	560	1400	800	1900	1000	3000	1600	3700	2000	4500	2300	6000	3100
750	—	—	380	190	400	220	600	330	800	450	1000	600	1510	850	2000	1100	3100	1800	4000	2300	5000	2600	6700	3500

4.0 CARATTERISTICHE ELETTRICHE MOTORI TRIFASE

4.0 ELECTRICAL CHARACTERISTICS THREEPHASE MOTORS

4.0 ELEKTRISCHE MERKMALE DREHSTROMMOTOREN

4.1 Potenza

I valori di potenza riportati nelle tabelle di selezione sono calcolati per servizio continuo (S1) con temperatura ambiente max di 40 °C, altitudine inferiore a 1000 msl, alimentazione a tensione nominale, frequenza a 50Hz e valgono anche nel caso in cui la tensione nominale subisca delle variazioni contenute fra + 5% e - 5%. Per condizioni operative e ambientali diverse, interpellare il ns. Servizio Clienti.

4.1 Power

Motor ratings listed in our selection tables are calculated for continuous duty (S1) in an ambient temperature of max 40°C, altitude below 1000 mt asl, normal voltage and 50Hz frequency. These values remain constant also in case of tension variations between + 5% and - 5%. For operating conditions different from the above, it is advisable to contact our Customer Service.

4.1 Leistung

Die in den Auswahltabellen angegebenen Leistungen sind für Dauerbetrieb (S1), Umgebungstemperatur von max. 40°C, Höhenlage unter 1000 m ü.M., Nennstromversorgung und Frequenz von 50 Hz berechnet. Sie gelten auch bei Nennspannung mit kleinen Schwankungen zwischen + 5% und -5%. Bei anderen Arbeits- oder Umgebungsbedingungen wenden Sie sich bitte an unseren Kundendienst.

4.2 Tensione e frequenza

I valori di tabella sono relativi a tensione nominale 230 - 400 V e 50 Hz. E' ammessa tolleranza di tensione $\pm 5\%$. Se un motore normale viene impiegato a 60 Hz, indicativamente occorre considerare le seguenti variazioni:

4.2 Frequency and tension

Values given in the table are relevant to nominal tension 230 - 400 V and 50Hz. It is allowable a tension tolerance of $\pm 5\%$. Should a standard motor be used at 60Hz, the following variations have to be considered:

4.2 Spannung und Frequenz

Die Tabellenwerte beziehen sich auf eine Nennspannung von 230 - 400 V und 50 Hz. Spannungstoleranzen von $\pm 5\%$ sind zulässig. Wird ein normaler Motor bei 60 Hz betrieben, müssen folgende Variationen berücksichtigt werden:

P_N	C°	$\cos\phi$	M_N	M_{MAX}/M_N	M_{sp}/M_N	n
=	=	=	- 17%	- 15%	- 30%	+ 20%

4.3 Classe di isolamento

Gli avvolgimenti, realizzati con filo a doppio smalto al massimo della tolleranza e sottoposti ad impregnazione sotto vuoto, sono isolati in **classe F** garantendo in tal modo un margine termico massimo di 155 °C, conforme alle prescrizioni delle principali normative. Per particolari applicazioni è possibile fornire (a richiesta) l'isolamento in classe H e motori sottoposti a trattamenti speciali per renderli atti a funzionare in ambienti umidi e corrosivi.

4.3 Insulation class

Windings are made of copper wire with double thickness enamelling and are subjected to vacuum impregnation. They are also **class F** insulated granting a maximum thermal margin of 155 °C according to the main specifications. For particular applications it is possible to supply (upon request) class H insulated motors. Specially treated motors suitable to operate in humid and corrosive ambients are also available upon request.

4.3 Isolationsklasse

Die Wicklungen aus Draht mit doppelter Lackschicht bei maximaler Toleranz und mit Vakuum Imprägnierung sind nach **Klasse F** isoliert und garantieren somit einen den einschlägigen Normen entsprechenden maximalen Temperaturgrenzwert von 155°C. Für besondere Anforderungen können die Motoren auf Anfrage mit einer Isolierung nach Klasse H und speziellen Schutzbehandlungen für feuchte und korrodierende Arbeitsumgebungen geliefert werden.

4.4 Schemi di collegamento motori trifase

4.4 Threephase motor wiring diagram

4.4 Schaltungsplan für Drehstrommotoren

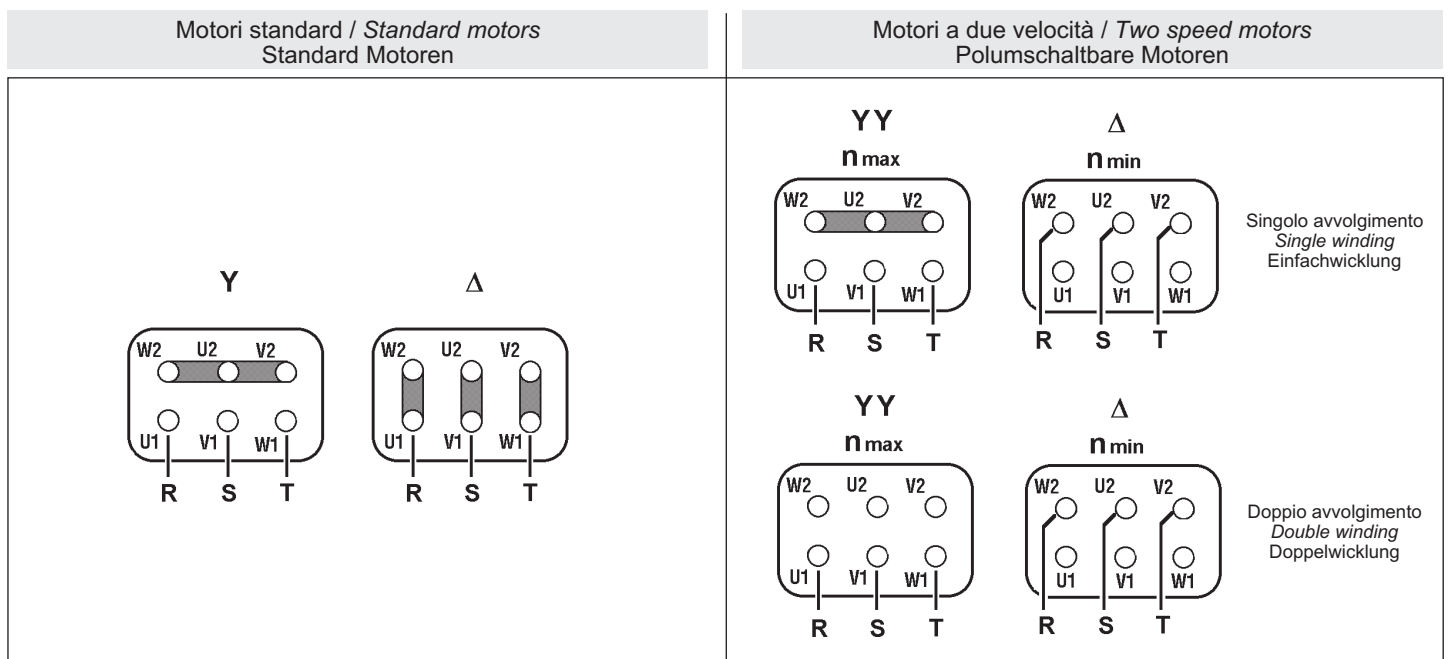

5.0 CARATTERISTICHE ELETTRICHE MOTORI MONOFASE

5.1 Generalità

I motori monofase MT sono dotati di un condensatore di marcia sempre inserito e collegato in serie all'avvolgimento sussidiario di avviamento.

I dati tecnici riportati nelle tabelle sono riferiti a condizioni di esercizio continuo a corrente alternata 230 V - 50 Hz.

Le dimensioni sono identiche a quelle dei motori trifase, fatta eccezione per l'ingombro della scatola morsettiera.

Il condensatore viene montato in una apposita scatola porta condensatore di materiale plastico che viene applicata al posto della vecchia scatola morsettiera di alluminio.

I motori monofase autofrenanti sono dotati di un freno a c.c.

5.2 Alta coppia di spunto (XN-XF)

Nelle applicazioni dove è richiesta una coppia di spunto elevata, i motori monofase potranno essere dotati (a richiesta) di un condensatore ausiliario, inserito solo nella fase di avviamento, che permette una coppia di spunto del 200%. Ad avviamento avvenuto, il condensatore ausiliario viene disinserito tramite un relé elettronico.

Frequenza avviamenti: 1 ogni 7 secondi.

5.3 Classe di isolamento e protezione

Come i motori trifase, anche i monofase sono realizzati con isolamento corrispondente alla classe F e protezione IP 55.

5.4 Senso di rotazione

I motori vengono forniti con senso di rotazione antiorario guardando l'albero. Gli schemi sotto riportati indicano i collegamenti da effettuare per ottenere un determinato senso di rotazione dell'albero del motore monofase (osservato di fronte).

5.5 Avvolgimento simmetrico

A richiesta, i motori elettrici monofase possono essere forniti con un avvolgimento simmetrico per consentire il funzionamento in entrambi i sensi di marcia senza necessità di arresto del motore. Lo schema sottoriportato indica il collegamento necessario per ottenere il senso di rotazione desiderato.

5.6 Schemi di collegamento motori monofase

5.0 ELECTRICAL CHARACTERISTICS SINGLE PHASE MOTORS

5.1 General

MT single phase motors are equipped with a run capacitor permanently turned on and connected to the auxiliary winding for starting.

Technical data reported in the tables are referred to continuous duty conditions at alternating current 230V - 50 Hz.

Overall dimensions are identical to the threephase motors, except for the terminal box.

The capacitor is assembled inside a special box in plastic which is mounted on the place of the old aluminium terminal box.

Single phase brake motors are equipped with a d.c. brake.

5.2 High starting torque (XN-XF)

In those applications where a high starting torque is required, single phase motors can be equipped (upon request) with an auxiliary capacitor which is connected only in the starting phase and allows a starting torque of 200%. Once the motor has been started, the auxiliary capacitor is disconnected by means of an electronic relay.

Start frequency: 1 every 7 seconds.

5.3 Insulation class and protection

Single phase motors are supplied with insulation class F and IP55 protection as well as the threephase ones.

5.4 Direction of rotation

Motors are supplied with anticlockwise rotation looking at the shaft. The diagrams underneath indicate the connections to be effected in order to obtain a determined direction of the rotation on the single phase motor shaft (seen from the front).

5.5 Symmetrical winding

Upon request single phase electric motors can be supplied with a symmetrical winding in order to allow them to operate in both directions of rotation without stopping the motor. The diagram indicates the connection necessary to obtain the required direction of rotation.

5.6 Single phase motor wiring diagram

5.0 ELEKTRISCHE MERKMALE EINPHASENMOTOREN

5.1 Allgemeines

Die MT-Einphasenmotoren sind mit einem ständig aktivierten, in Serie zur Hilfs-Anlaufwicklung geschalteten Kondensator ausgestattet.

Die technischen Daten in der Tabelle beziehen sich auf Dauerbetrieb mit Ws-Versorgung von 220 V - 50 Hz.

Die Abmessungen stimmen, mit Ausnahme der Außenmasse der Klemmenkasten, genau mit denen der Drehstrommotoren überein.

Der Kondensator wird montiert in eine sonder Kunststoffklemmenkasten. Diese neuere Kunststoffklemmenkasten wird montiert auf die gleiche Sitz von die Alte Klemmenkasten.

Die Einphasenbremsmotoren sind mit Gs-Bremse ausgestattet.

5.2 Hohes Anlaufmoment (XN-XF)

Bei Anwendungen, wo eine hohes Anlaufmoment erforderlich ist, können die Einphasenmotoren auf Anfrage mit einem nur in der Anlaufphase aktivierten Hilfskondensator ausgerüstet werden, der ein 200% iges Anlaufmoment ermöglicht. Nach dem Start wird dieser Hilfskondensator mit einem elektronischen Relais ausgeschaltet.

Schaltungshäufigkeit: 1 alle 7 Sekunden.

5.3 Isolationsklasse und Schutzart

Auch die Einphasenmotoren sind wie die Drehstrommotoren in der Isolationsklasse F und in der Schutzart IP55 gebaut.

5.4 Drehrichtung

Die Drehrichtung der Motoren ist, von der Welle aus betrachtet, gegen den Uhrzeigersinn. Die nachstehenden Anschlußpläne gelten für bestimmte Drehrichtungen der Welle des Einphasenmotors (von vorne betrachtet).

5.5 Symmetrische Wicklung

Auf Anfrage können die Einphasen-Elektromotoren mit einer symmetrischen Wicklung für den Betrieb in beide Laufrichtungen, ohne Anhalten des Motors, ausgerüstet werden. Nachstehend das Anschlußschema für die gewünschte Drehrichtung.

5.6 Anschlußpläne für Einphasenmotoren

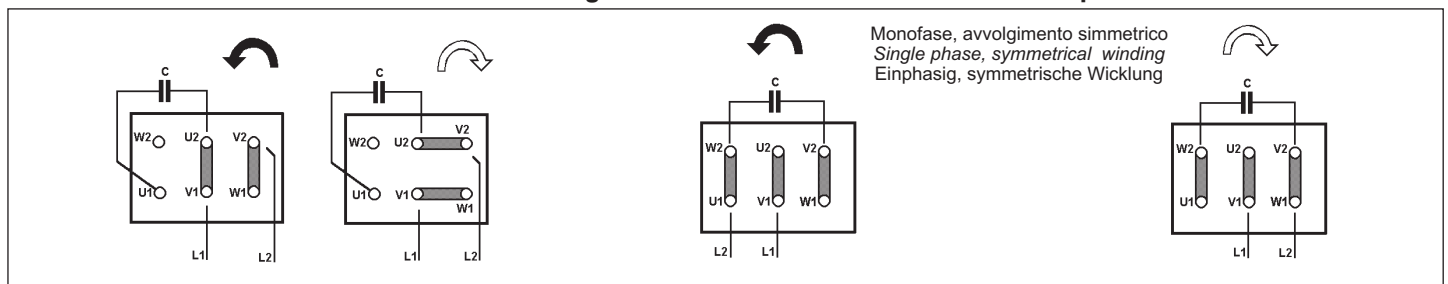

6.1 Generalità

I motori autofrenanti nascono dalla applicazione, su un motore a corrente alternata, di un freno elettromagnetico a disco ad azione negativa che interviene, quindi, in mancanza di corrente causando l'arresto del motore e quant'altro da esso comandato.

Il motore autofrenante garantisce quindi una grande precisione d'arresto in caso di interruzione volontaria della corrente; garantisce inoltre un elevato grado di sicurezza se l'interruzione è accidentale. La pressione di frenatura è esercitata con rapidità da una o più molle al cessare dell'azione dell'elettromagnete.

Le principali caratteristiche si possono così riassumere:

- Esecuzione possibile su motori trifase e monofase
- Possibilità di avere l'albero bisporgente
- Possibilità di alimentazione separata del freno. Questa soluzione è adottata sui motori a doppia polarità e quando si utilizzano un inverter
- Frenatura ugualmente efficace nei due sensi di rotazione senza spostamento assiale dell'albero
- Semplice regolazione del traferro a freno montato
- Possibilità di regolazione della coppia frenante

Nel motore autofrenante trifase standard è prevista l'applicazione di freni alimentati a c.a.; su richiesta possono essere forniti freni in c.c.

I motori monofase autofrenanti sono sempre dotati di un freno a c.c.

6.2 Protezione e isolamento

Il motore autofrenante viene realizzato con isolamento in classe F e protezione IP54 (IP55 a richiesta).

6.3 Leva di sblocco

A richiesta può essere fornita la leva di sblocco manuale meccanico (fig. 1).

6.1 General

Brake motors are made with the application of an electromagnetic disc-brake onto an a.c. motor which operates in case of lack of current causing the blocking of the motor and of the other devices connected to it.

The brake motor grants a high stop precision in case of voluntary interruption of current; it grants also a high safety margin should the interruption be accidental.

Braking pressure is effected in a very fast way from one or more springs once the electromagnet stops its action.

The principal characteristics can be summed up as follows:

- *Execution available on threephase and single phase motors*
- *Double extended shaft*
- *Possibility of brake separate feeding. This solution is advisable on two speed motors and when an inverter is used.*
- *Braking action effective in both directions of rotation without axial movement of the shaft.*
- *Simple adjustment of the air gap once the brake is assembled*
- *Possibility of braking torque setting*

The standard three-phase brake motor is supplied with AC brakes, upon request DC brakes are also available.

The single-phase brake motors are always equipped with a DC brake.

6.2 Protection and insulation

Brake motors are supplied with insulation class F and IP54 protection (IP55 on request).

6.3 Hand release

Upon request, mechanical hand brake release can be supplied (fig. 1).

6.1 Allgemeines

Die Bremsmotoren entstehen durch die Ausrüstung eines Wechselstrommotors mit einer elektromagnetischen Scheibenbremse mit Negativwirkung, die bei Stromausfall den Motor und die damit angetriebenen Geräte anhält.

Der Bremsmotor garantiert deshalb eine hohe Stoppgenauigkeit bei gewollter Stromunterbrechung und einen hohen Sicherheitsgrad bei versehentlicher Unterbrechung.

Der Bremsdruck wird bei Deaktivierung des Elektromagneten sofort durch eine oder mehrere Federn erzeugt.

Die Hauptmerkmale sind:

- Möglichkeit zur Montage auf alle Drehstrom- und Einphasenmotoren
- Auf Wunsch mit doppelt vorstehender Welle
- Auf Wunsch mit separater Bremsversorgung. Diese Lösung empfiehlt sich bei Motoren mit doppelter Polung und bei Benutzung eines Inverters
- Gleiche Bremsleistung in beide Drehrichtungen, ohne Achsenverschiebung der Welle
- Einfache Luftspaltregelung bei montierter Bremse
- Regelbares Bremsmoment

Bei den dreiphasigen Drehstrom-Bremsmotoren in Standardversion ist der Einbau von Ws-Bremsen vorgesehen. Auf Anfrage kann der Motor auch mit Gs-Bremsen geliefert werden.

Die einphasigen Bremsmotoren sind stets mit Gs-Bremsen ausgestattet.

6.2 Schutzart und Isolation

Der Bremsmotor wird in der Isolationsklasse F und der Schutzart IP54 gebaut (IP55 auf Anfrage).

6.3 Entsperrhebel

Auf Anfrage ist ein Hebel für die manuelle Entsperrung der Bremse lieferbar (fig. 1).

fig. 1

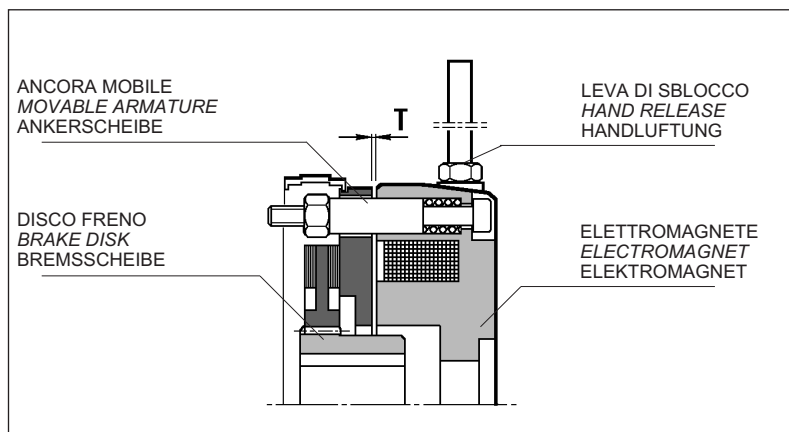

7.1 Caratteristiche tecniche del freno a c.a.

7.1 A.C. brake technical characteristics

7.1 Technische Merkmale der Ws-Bremse

Motore Motor	Mmin* Nm	Mmax Nm	Pf W	IN (400V) A	J Kgm ²	T mm	Tn mm	g _{min} mm	TEMPI DI INTERVENTO FRENO BRAKE INTERVENTION TIME BREMSAKTIVIERUNGSZEIT		Kg
									Ta ms	Tc ms	
63	2	5	18	0.08	6x10 ⁻⁵	0.2	0.5	1	20	4	1.25
71	4	10	25	0.11	11x10 ⁻⁵	0.2	0.5	1	40	4	1.9
80	7	20	30	0.15	16x10 ⁻⁵	0.3	0.6	1	60	6	3
90	14	40	35	0.36	35x10 ⁻⁵	0.3	0.6	1	90	8	5.6
100	26	70	45	0.65	88x10 ⁻⁵	0.35	0.7	1	120	16	9.7
112	35	100	55	0.78	103x10 ⁻⁵	0.35	0.7	1	140	16	10.3
132	53	150	75	0.90	225x10 ⁻⁵	0.40	0.8	1	180	16	14.7
160	85	250	170	1.20	600x10 ⁻⁵	0.50	0.8	1	200	20	24.5

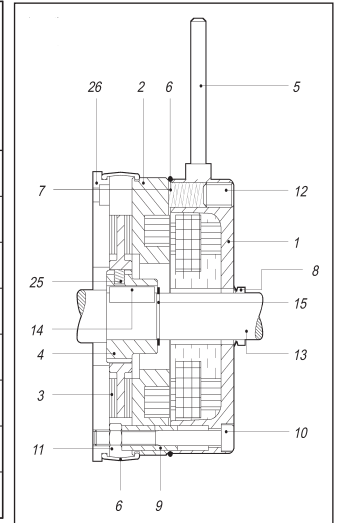

* N.B.
La coppia minima indicata è riferita alla configurazione standard con le viti A (pag. 11) completamente allentate.
Per ottenere dei valori inferiori è necessario sostituire le molle.
Tutti i motori autofrenanti sono forniti di serie con la coppia del freno tarata ad un valore pari al 70% circa della coppia massima.

* N.B.
The listed minimum torque refers to the standard configuration with screws A (page 11) completely loose.
Springs must be replaced in order to have lower values.
All brake motors in the standard version are supplied with a brake torque set to a valued equal to approx. 70% of the maximum torque.

* N.B.
Das angegebene Mindestdrehmoment bezieht sich auf die Standard-Konfiguration bei völlig gelösten Schrauben A (Seite 11).
Um niedrigere Werte zu erhalten, müssen die Federn ausgetauscht werden.
Alle Bremsmotoren sind serienmäßig mit einem Bremsmoment ausgestattet, das auf einen Wert von ca. 70% des Höchstdrehmomentes geeicht ist.

Mmin = Coppia frenante min
Mmax = Coppia frenante max
J = Momento d'inerzia bussola
T = Valore minimo regolazione traferro
Tn = Valore max traferro prima della nuova regolazione
g_{min} = Spessore minimo residuo ferodo
Ta = Tempo di apertura freno
Tc = Tempo di chiusura freno
IN = Corrente assorbita a 400V
Pf = Potenza assorbita dal freno

Mmin =Min braking torque
Mmax =Max braking torque
J = Moment of inertia of magnet
T = Min. value of air gap setting
Tn = Max value of air gap before new setting adjustment
g_{min} = Min thickness of brake lining
Ta = Brake opening time
Tc = Brake closing time
IN = Absorbed current at 400V
Pf = Power absorbed by brake

Mmin =Min. Bremsmoment
Mmax =Max. Bremsmoment
J = Trägheitsmoment der Buchse
T = Min. Luftspaltwert
Tn = Max. Luftspaltwert vor Neueinstellung
g_{min} = Mindeststärke Bremsbelag
Ta = Öffnungszeit der Bremse
Tc = Schließzeit der Bremse
IN = Nennstrom der Bremse bei 400V
Pf = Leistungsaufnahme der Bremse

Il freno a c.a. è fornito di serie con i seguenti valori di alimentazione:

A.C. brake is supplied with following feeding values:

Die Ws-Bremse wird serienmäßig mit folgenden Versorgungsspannungen:

Motore	Alimentazione motore (V)	Alimentazione freno (V)
Trifase standard	230/400	230/400
Trifase doppia polarità	230	230/400
	400	

Motor	Motor feeding (V)	Brake feeding (V)
Threephase standard	230/400	230/400
Threephase double polarity	230	230/400
	400	

Motor	Motorspannung (V)	Bremsspannung (V)
Drehstrom standard	230/400	230/400
Drehstrom Polumschalt.Mot.	230	230/400
	400	

A richiesta è possibile fornire il freno con alimentazione separata. Questa soluzione è consigliata per motori a due velocità o in caso di alimentazione tramite inverter.
Numero max. di interventi: 20 al minuto.

Upon request it is possible to supply brakes with separate feeding. This solution is advisable on two speed motors or in those cases where feeding is obtained by means of an inverter.
Maximum number of starts: 20 for minute.

Auf Anfrage ist eine separate Bremsversorgung erhältlich. Diese Lösung empfiehlt sich bei Polumschaltbaren-Motoren oder bei invertergesteuerten Motoren.
Maximale Schaltungsanzahl: 20 pro Minute.

8.0 FRENO A C.C.

8.0 D.C. BRAKE

8.0 Gs - BREMSE

8.1 Caratteristiche tecniche del freno a c.c.

8.1 D.C. brake technical characteristics

8.1 Technische Merkmale der Gs-Bremse

Motore Motor	M _{min} * Nm	M _{max} Nm	J Kg ^m ²	I (230V) A	T mm	T _n mm	g _{min} mm	TEMPI DI INTERVENTO FRENO BRAKE INTERVENTION TIME BREMSAKTIVIERUNGSZEIT				Kg
								Ta ₁ ms	Ta ₂ ms	FAST Tc ₁ ms	STAND. Tc ₂ ms	
56	1.5	3	1.2x10 ⁻⁵	0.15	0.20	0.35	1	—	—	12	30	1.1
63	2	5	6x10 ⁻⁵	0.18	0.20	0.50	1	100	10	20	30	1.5
71	4	10	11x10 ⁻⁵	0.25	0.20	0.50	1	120	10	25	60	2.2
80	7	20	16x10 ⁻⁵	0.30	0.30	0.60	1	150	10	40	100	3.1
90	14	40	35x10 ⁻⁵	0.40	0.30	0.60	1	220	15	50	120	4.9
100	26	70	88x10 ⁻⁵	0.45	0.35	0.70	1	300	30	80	—	8.3
112	35	100	103x10 ⁻⁵	0.60	0.35	0.70	1	200	20	80	—	9.5
132	53	150	225x10 ⁻⁵	0.60	0.40	0.80	1	200	20	100	—	13.5
160	85	250	600x10 ⁻⁵	0.90	0.50	0.80	1	300	30	150	—	24.8

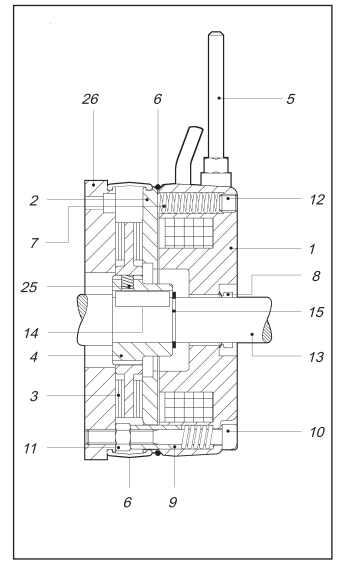

* N.B.

La coppia minima indicata è riferita alla configurazione standard con le viti A (pag. 11) completamente allentate.

Per ottenere dei valori inferiori è necessario sostituire le molle.

Tutti i motori autofrenanti sono forniti di serie con la coppia del freno tarata ad un valore pari al 70% circa della coppia massima.

I = Corrente assorbita dal freno a 230V

M_{min} = Coppia frenante min

M_{max} = Coppia frenante max

J = Momento d'inerzia bussola

T = Valore minimo regolazione traferro

T_n = Valore max traferro prima della nuova regolazione

g_{min} = Spessore minimo residuo ferodo

Ta₁ = Tempo di apertura freno AC

Ta₂ = Tempo di apertura freno DC

Tc₁ = Tempo di chiusura con dispositivo fast. **(a richiesta)**

Tc₂ = Tempo di chiusura standard

* N.B.

The listed minimum torque refers to the standard configuration with screws A (page 11) completely loose. Springs must be replaced in order to have lower values.

All brake motors in the standard version are supplied with a brake torque set to a value equal to approx. 70% of the maximum torque.

I = Absorbed current at 230V

M_{min} = Min braking torque

M_{max} = Max braking torque

J = Moment of inertia of magnet

T = Min. value of air gap setting

T_n = Max value of air gap before new setting

adjustement

g_{min} = Min thickness of brake lining

Ta₁ = Brake opening time AC

Ta₂ = Brake opening time DC

Tc₁ = Brake closing time with fast device **(upon request)**

Tc₂ = Standard brake closing time

* N.B.

Das angegebene Mindestdrehmoment bezieht sich auf die Standard-Konfiguration bei völlig gelösten Schrauben A (Seite 11).

Um niedrigere Werte zu erhalten, müssen die Federn ausgetauscht werden.

Alle Bremsmotoren sind serienmäßig mit einem Bremsmoment ausgestattet, das auf einen Wert von ca. 75% des Höchstdrehmomentes geeicht ist.

I = Nennstrom der Bremse bei 230V

M_{min} = Min. Bremsmoment

M_{max} = Max. Bremsmoment

J = Trägheitsmoment der Buchse

T = Min. Luftspaltwert

T_n = Max. Luftspaltwert vor Neueinstellung

g_{min} = Mindeststärke Bremsbelag

Ta₁ = Öffnungszeit der Bremse AC

Ta₂ = Öffnungszeit der Bremse DC

Tc₁ = Schliesszeit der Bremse mit Fastvorrichtung **(auf Anfrage)**

Tc₂ = Standard-Schließzeit der Bremse

Il freno a c.c. è fornito di serie con i seguenti valori di alimentazione:

Motore	Alimentazione motore (V)	Alimentazione freno (V)
Trifase standard	230/400	103
Trifase doppia polarità	230	103
	400	178
Monofase	230	103

A richiesta è possibile fornire il freno con alimentazione separata.
Numero max. interventi: 20 al minuto.

N.B. Quando si utilizzano motori autofrenanti a doppia polarità o motori comandati da inverter, si consiglia di adottare l'alimentazione separata del freno.

D.C. brake is supplied with following feeding values:

Motor	Motor feeding (V)	Brake feeding (V)
Threephase standard	230/400	103
Threephase double polarity	230	103
	400	178
Single phase	230	103

Upon request it is possible to supply separate feeded brakes.
Maximum number of starts: 20 for minute.

N.B. When two speed brake motors or motors operated through inverters are used, it is advisable to adopt brakes with separate feeding.

Die Gs-Bremse wird serienmäßig mit folgenden Versorgungsspannungen:

Motor	Motorspannung (V)	Bremsspannung (V)
Drehstrom standard	230/400	103
Drehstrom Polumschalt. Mot.	230	103
	400	178
Einphasen	230	103

Auf Anfrage ist eine separate Bremsenversorgung erhältlich.
Maximale Schaltungsanzahl: 20 pro Minute.

N.B. Bei Bremsmotoren (Polumschaltbar oder mit Invertersteuerung) empfiehlt sich eine separate Bremsversorgung.

8.0 FRENO A C.C.

8.0 D.C. BRAKE

8.0 Gs - BREMSE

8.2 Raddrizzatori di corrente

8.2 Current rectifiers

8.2 Gleichrichter

Tutti i raddrizzatori utilizzati nei nostri motori sono conformi alla Direttiva Bassa Tensione (LVD) 73/23/CEE e successive modifiche.

I tipi da noi utilizzati sono i seguenti:

RV9 per le gr. 56-63-71

NBR 500-1 (colore blu) per le gr. 80 e 90 (fig. 2);

SBR 440-1 (colore rosso) dalla gr. 100 alla gr. 200 (fig. 3).

All the current rectifiers used with our motors comply with the Low Voltage Directives EEC/73/23 and following changes.

The types we use are the following:

RV9 for sizes 56-63-71

NBR 500-1 (blue color) for sizes 80 and 90 (fig. 2);

SBR 440-1 (red colour) from size 100 to size 200 (fig. 3).

Alle in unseren Motoren verwendeten Gleichrichter entsprechen der Richtlinie bezüglich der Niedrig-Spannung (LVD) 73/23/CEE und deren nachfolgenden Änderungen.

Wir verwenden die folgenden Typen:

RV9 für die Baugrößen 56-63-71

NBR 500-1 (Farbe blau) für die Baugrößen 80 und 90 (Abb. 2);

SBR 440-1 (Farbe rot) von Baugröß100 bis Baugröß 200(Abb. 3)

fig. 2

Tempi di intervento con raddrizzatori tipo NBR
Time of intervention with rectifiers NBR
Anspruchzeit mit Gleichrichtern vom Typ NBR

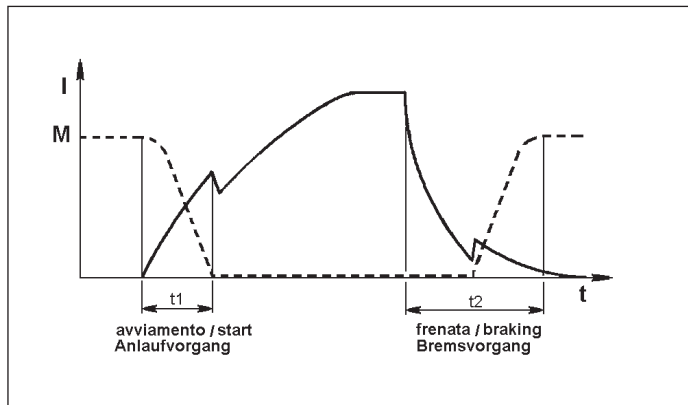
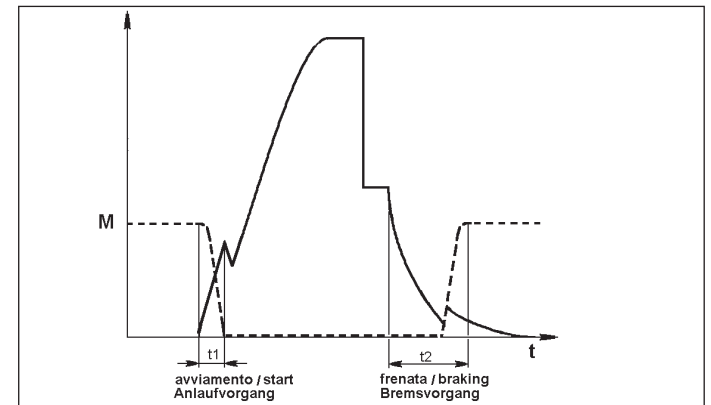

fig. 3

Tempi di intervento con raddrizzatori tipo SBR
Time of intervention with rectifiers SBR
Anspruchzeit mit Gleichrichtern vom Typ SBR



Nei motori standard ad una polarità alimentando il motore si ha la conseguente alimentazione del raddrizzatore in quanto esso è collegato alla morsetteria.

Quando si utilizzano motori autofrenanti a doppia polarità o motori comandati da inverter, si consiglia di adottare l'alimentazione separata del freno effettuando i collegamenti come indicato nelle fig.4 e fig. 5 per i tipi NBR 500-1 e SBR 440-1.

In the standard single-pole motors, the rectifier is powered through the motor as the rectifier is connected to the terminal board.

If two-pole brake motors or motors controlled by inverters are used, we suggest to power the brake separately as shown in fig. 4 and 5 for type NBR 500-1 and SBR 440-1.

Bei den einpoligen Standard-Motoren wird mit der Motorspeisung gleichzeitig der Gleichrichter gespeist, da dieser an die Klemmleiste angeschlossen ist.

Werden zweipolige Bremsmotoren oder durch Frequenzrichter gesteuerte Motoren verwendet, so empfiehlt sich eine separate Speisung der Bremse. Dabei werden die Anschlüsse wie in den Abbildungen 4 und 5 für die Typen NBR 500-1 und SBR 440-1.

fig. 4 Frenata normale / Standard braking / Normaler Bremsvorgang

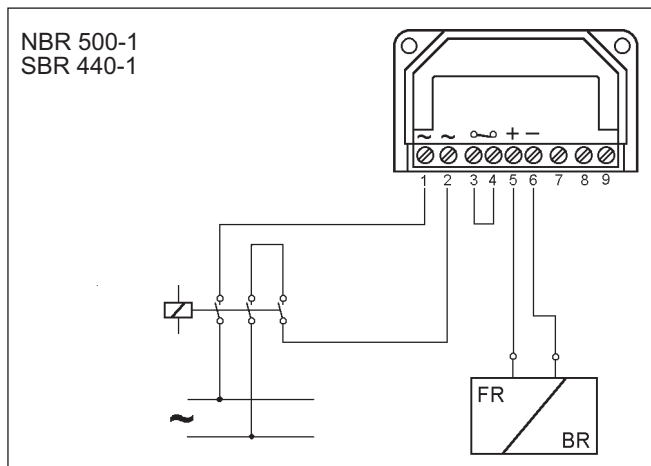
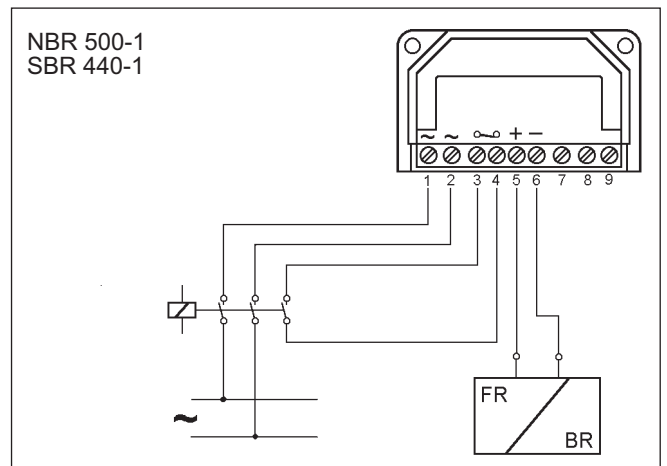

fig. 5 Frenata rapida / Fast braking / Schneller Bremsvorgang



9.0 VERIFICHE E REGOLAZIONI

Tutti i motori vengono collaudati e la taratura dei freni viene effettuata ad un valore pari al 70% circa della coppia massima in base a una tensione di alimentazione di 400 Volt.

Nel caso in cui, si avvertano vibrazioni nel freno è opportuno effettuare i seguenti controlli e relativi interventi per riportare il sistema alle normali condizioni operative:

1) Verificare la tensione di alimentazione. Se essa è inferiore a 400 Volt provvedere a riportarla al valore nominale oppure intervenire riducendo la pressione delle molle agendo come indicato al punto 3.

2) Verifica del traferro. Con uno spessore misurare il traferro T (distanza fra l'elettromagnete e l'ancora mobile) controllando che il valore rilevato rientri nel campo indicato in tabella.

Se questa condizione non fosse verificata, sarà necessario effettuare la regolazione allentando i dadi B e agendo sulle viti C fino a che il traferro non avrà raggiunto il valore prestabilito.

Ad operazione conclusa stringere nuovamente i dadi B.

Questo controllo e l' eventuale intervento dovranno essere effettuati periodicamente ad intervalli stabiliti in base all' utilizzo del freno.

Nel caso in cui sia montata la leva di sblocco è necessario verificare che un eccessivo valore del traferro comporti l'annullamento della coppia frenante dovuto alla ripresa del gioco della leva stessa. Nelle tabelle è riportato il valore max del gioco della leva (X).

3) Regolazione della coppia frenante. La coppia frenante è proporzionale alla compressione delle molle E ed è possibile variarla agendo sulle viti A (n°3 per motori grand. 63 - 112 e n° 6 per grand. 132 - 160) in successione e in modo uniforme; a tale proposito si consiglia di effettuare una rotazione di 1/2 giro a ciascuna vite di regolazione e riprovare il funzionamento del freno.

Il grafico di fig. 6 indica (in valori percentuali) le coppie frenanti ottenibili in base ai giri di avvitamento dei grani.

9.0 CHECKS AND ADJUSTMENTS

All motors are tested and brakes are set to a value equal to 70% of the maximum torque based on a 400 V supply voltage.

Should vibrations be noticed in the brake, it is advisable to check as indicated below and carry out the relative operations to bring the system back to normal working conditions:

1) Check the supply tension. Should it be lower than 400 Volts, bring it back to the nominal value or reduce the pressure of the springs by regulating as indicated at point 3.

2) Checking the magnetic gap. Using a feeler gauge, measure the T magnetic gap (distance between the electromagnet and the mobile keeper) checking that the measured value falls within the range indicated in the chart. Should this condition not occur, an adjustment must be made by unloosening screw nuts B and by regulating screws C until the magnetic gap has reached the preset value.

When this operation is finished, tighten screw nuts B.

This check and the relative adjustment, if performed, must be carried out periodically at intervals set according to how much the brake is used.

If the release lever has been assembled, it is necessary to check if the high value of the magnetic gap has determined the no intervention of the braking torque due to the clearance of the lever itself.

The maximum value of the lever clearance (X) is shown in the table.

3) Adjusting the braking torque.

The braking torque is proportional to the compression of springs E and it is possible to change it by regulating the dowels A (3 for the motor size 63-112, 5 for the motor size 132-160) in sequence and in a uniform manner; on this matter, it is advisable to rotate each screw by 1/2 turn and retry the brake functioning.

The fig. 6 show the braking torques (in % values) referred to the number of screw turns.

9.0 KONTROLLEN UND EINSTELLUNGEN

Alle Motoren werden zugelassen und die Eichung der Bremsen wird bei einem Wert von 70 % des Höchstdrehmomentes bei einer Versorgungsspannung von 400 Volt ausgeführt.

Sollten in der Bremse Vibrationen festgestellt werden, so sollten die folgenden Kontrollen und die entsprechenden Instandsetzungsarbeiten durchgeführt werden, um das System wieder auf die normalen Betriebsbedingungen zurückzuführen:

1.) Die Versorgungsspannung überprüfen. Sollte diese unter 400 Volt liegen, so sollte sie auf den Nominalwert zurückgeführt werden. Andernfalls kann die Spannung der Federn reduziert werden, indem wie unter Punkt 3 beschrieben vorgegangen wird.

2.) Den Luftspalt überprüfen. Mit einem Dickenmesser den Luftspalt T (Distanz zwischen Elektromagnet und Ankerscheibe) abmessen und dabei überprüfen, ob der festgestellte Wert innerhalb des in der Tabelle angegebenen Bereiches liegt.

Sollte dies nicht der Fall sein, muß die Einstellung neu ausgeführt werden. Dazu die Schraubenmuttern B lösen und die Schrauben C drehen, bis der Luftspalt den vorgeschriebenen Wert erreicht. Ist dies geschehen, so müssen die Schraubenmuttern B wieder angezogen werden.

Diese Kontrolle und die eventuell erforderliche Neueinstellung sollten regelmäßig in Intervallen, die den Einsatzzeiten der Bremse entsprechen, ausgeführt werden.

Sollte eine Handlüftung installiert sein, so sollte überprüft werden, ob ein übermäßiger Wert des Luftspaltes nicht zu einer Annullierung des Drehmomentes führt, die auf den Ausgleich des Spiels des Hebels selbst zurückzuführen ist. In der Tabelle ist der Höchstwert des zulässigen Spiels des Hebels (X) aufgeführt.

3) Einstellung des Bremsmoments. Das Bremsmoment ist proportional zur Druckspannung der Federn E und es kann durch aufeinanderfolgendes und gleichmäßiges Einwirken auf die Stifte A (3 für die Größen 63-112 und 6 für die Größen 132-160) variiert werden. Diesbezüglich ist es empfehlenswert, jeweils eine halbe Drehung auf jeder Einstellungsschraube auszuführen und dann den Betrieb der Bremse erneut zu überprüfen. Die Grafik in der Abbildung 6 gibt (in Prozentwerten) die möglichen Bremsmomente je nach den Verschraubungsumdrehungen der Stifte an.

fig. 6

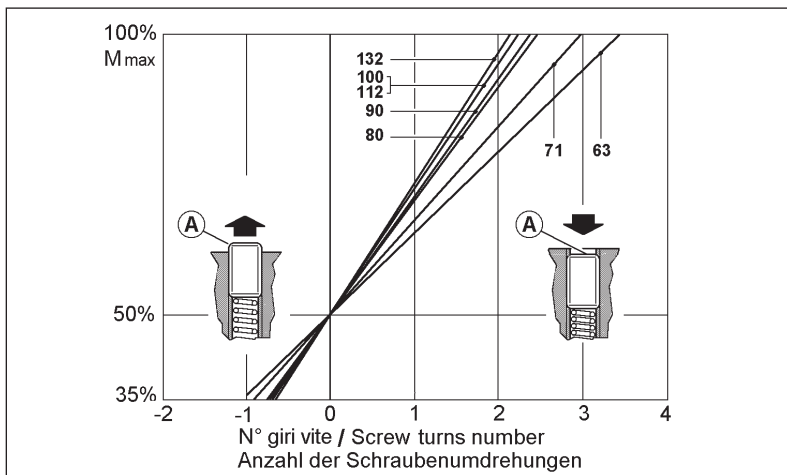

9.0 VERIFICHE E REGOLAZIONI

Se alimentando il freno l'elettromagnete non riesce a richiamare l'ancora mobile e a tenerla attratta senza vibrazioni è necessario ridurre la pressione delle molle allentando (in modo uniforme) le viti A. Questa regolazione dovrà essere effettuata prevedendo una tensione di alimentazione inferiore del 10 - 15% alla nominale.

4) Sostituzione elettromagnete.
Nel caso in cui si rendesse necessario questo intervento, togliere il copriventola e la ventola, scollegare dalla morsettiera i cavi di alimentazione dell'elettromagnete, allentare i dadi B e svitare le viti C.

9.0 CHECKS AND ADJUSTMENTS

If, by feeding the brake, the electromagnet is unable to call back the mobile keeper and to keep it attracted without any vibrations, the pressure of the springs must be reduced by loosening screws A (in a uniform manner). The adjustment shall be carried out considering a supply voltage 10 - 15% lower than the voltage rating.

*4) Replacing the electromagnet.
Should this regulation be necessary, remove the fan cover and the fan, disconnect the feed wires of the electromagnet from the terminal board, unloosen screw nuts B and unscrew screws C.*

9.0 KONTROLLEN UND EINSTELLUNGEN

Sollte während der Speisung der Bremse der Elektromagnet nicht in der Lage sein, die Ankerscheibe anzuziehen und diese ohne Vibrationen in dieser Position zu halten, sollte die Druckspannung der Federn reduziert werden, indem die Schrauben A gleichmäßig gelöst werden. Diese Einstellung sollte ausgeführt werden, indem eine Versorgungsspannung, die um 10 - 15% unter der nominalen Versorgungsspannung liegt, angelegt wird.

4) Austausch des Elektromagnets
Sollte es sich als erforderlich erweisen, den Elektromagneten auszutauschen, so sollten die Lüfterhaube und der Lüfter entfernt, die Versorgungskabel des Elektromagneten von der Klemmenleiste abgenommen, die Schraubenmutter B gelöst und die Schrauben C abgeschraubt werden.

Freno a C.A.

A.C. brake

Ws-Bremse.

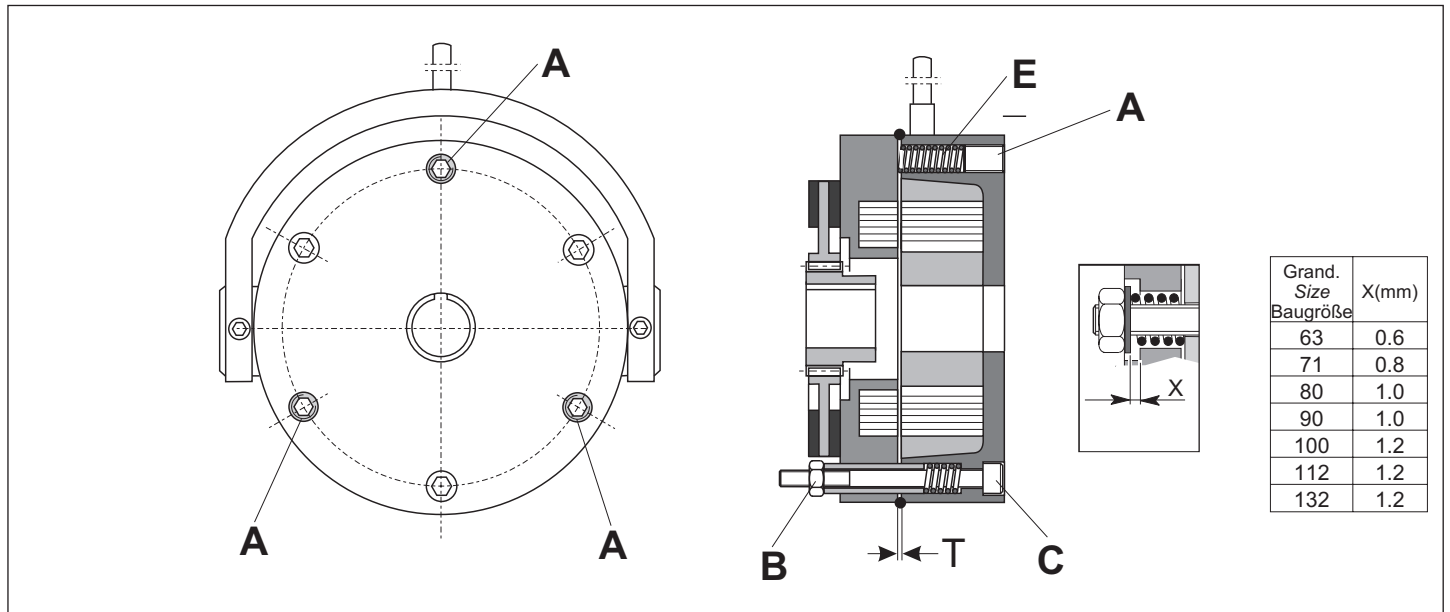

Freno a C.C.

C.C. brake

Gs-Bremse.

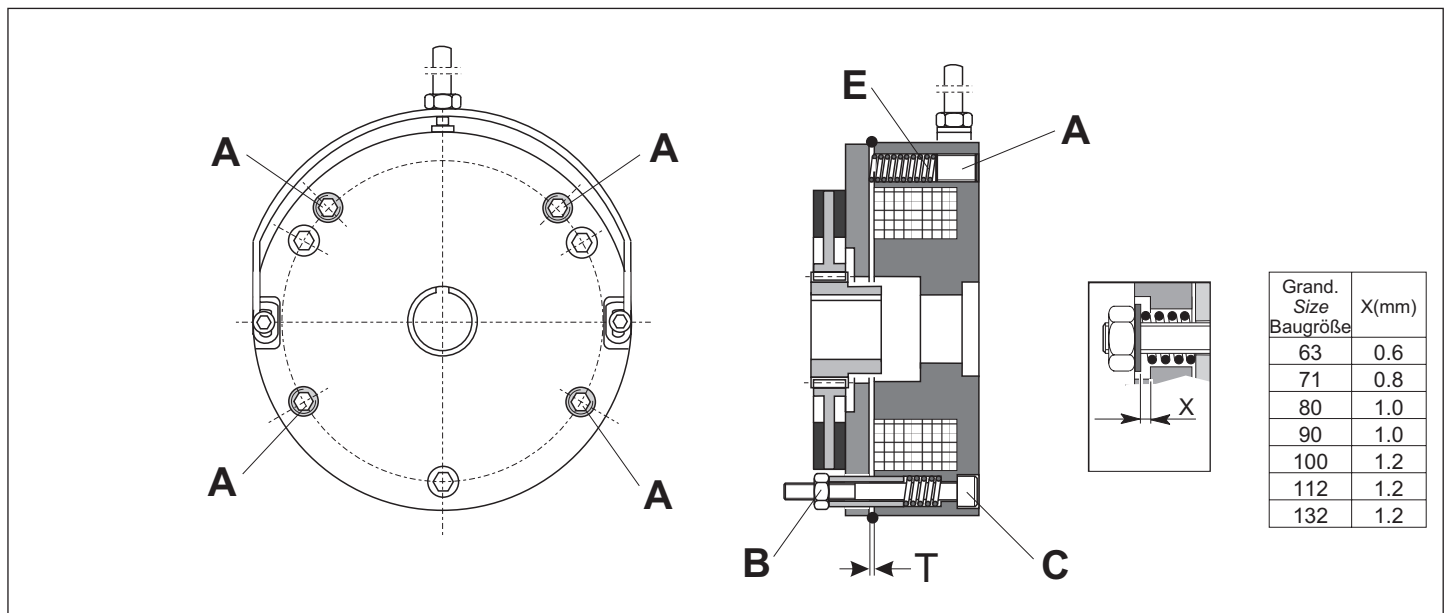

10.0 OPZIONI A RICHIESTA

10.0 OPTIONS UPON REQUEST

10.0 OPTIONAL AUF ANFRAGE

10.1 Motore elettroventilato

I motori elettrici MT possono essere dotati, a richiesta, di un sistema di ventilazione aggiuntivo alimentato in modo autonomo a V 230/50-60 Hz monofase e V 230-400/50 Hz trifase inserito all'interno della calotta copriventola.

Nelle tabelle seguenti sono indicate le relative variazioni dimensionali riferite ai motori normali e autofrenanti e gli assorbimenti di corrente (A) e le potenze (W).

Motore normale / Standard motor / Standard-Motor

TN-DN-MN	S1		I (A)		P (W)	
	~		~		~	
56	14	100	0.07	0.14	13	40
63	26	100	0.07	0.14	13	40
71	18	100	0.09	0.14	19	40
80	40	100	0.13	0.16	22	40
90	30	100	0.13	0.16	22	40
100	35	100	0.23	0.16	32	40
112	40	100	0.23	0.18	32	40
132	58	100	0.32	0.18	42	40
160	0	100	0.32	0.18	42	40

Motore autofrenante / Brake motor / Bremsmotor

TF-DF-MF	S1		I (A)		P (W)	
	~		~		~	
56	0	100	0.07	0.14	13	40
63	38	100	0.07	0.14	13	40
71	45	100	0.09	0.14	19	40
80	45	100	0.13	0.16	22	40
90	48	100	0.13	0.16	22	40
100	50	100	0.23	0.16	32	40
112	60	100	0.23	0.18	32	40
132	60	100	0.32	0.18	42	40
160	0	100	0.32	0.18	42	40

~ Servoventilazione monofase
Single phase servoventilation
Einphasenfremdlüfter

~ Servoventilazione trifase
Threephase servoventilation
Drehstromfremdlüfter

10.1 Motor with electric ventilation

Upon request, MT motors can be supplied with an additional ventilation system which is fed separately at V 230/50-60 Hz single phase and V 230-400/50 Hz threephase installed inside the fan cover.

Following tables show the size changes relating to the standard and brake motors and the current absorbed (A) and the nominal power (W).

10.1 Motor mit Elektrofremdlüfter

Die Elektromotoren MT können auf Anfrage mit einem zusätzlichen Lüftungssystem ausgestattet werden, welches autonom auf V 230/50-60 Hz Einphasen und V 230-400/50 Hz Drehstrom gespeist wird im Inneren der Lüfterhaube untergebracht ist. In den folgenden Tabellen sind die entsprechenden Abmessungsveränderungen bezüglich der Standard-Motoren und der Bremsmotoren und auch die Nennstrom (A) und die Nennleistungen (W) angegeben.

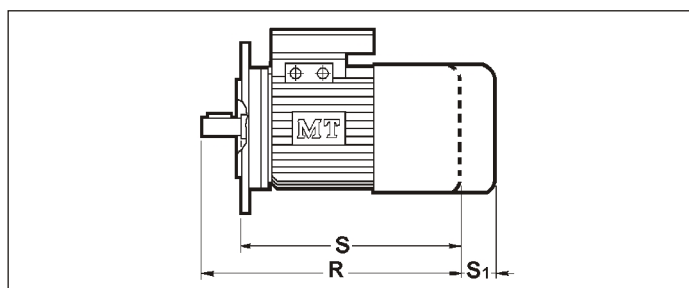
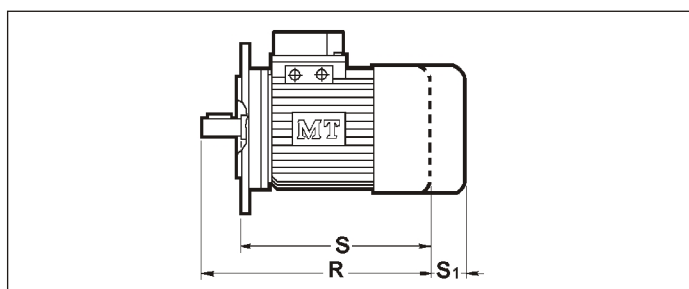

10.2 Volano

I motori autofrenanti possono essere forniti, su richiesta, con un volano che determina una maggiore progressività in fase di avviamento e in fase di frenatura. Le dimensioni del motore con volano sono le stesse del motore elettroventilato.

10.2 Flywheel

Upon request, the brake motors can also be supplied with a flywheel which determines a higher graduality in the starting and braking phases.

Sizes of the motors with flywheel are the same as the motor with electric ventilation.

10.2 Schwungrad

Die Bremsmotoren können auf Anfrage mit einem Schwungrad ausgestattet werden, welches eine größere Abstufbarkeit während der Anlaufphase und während der Bremsphase bewirkt.

Die Abmessungen des mit einem Schwungrad ausgestatteten Motors entsprechen denjenigen eines Motors mit Elektrofremdlüfter.

10.3 Tettuccio

Sulla calotta copriventola dei motori può essere applicato un tettuccio in lamiera con la funzione di protezione contro lo stillicidio o l'entrata di corpi estranei.

10.3 Cover

A sheet cover can be applied on to the fan cover in order to make it dripproof and to avoid foreign matters.

10.3 Schutzdach

Auf der Lüfterhaube der Motoren kann ein Blechdach angebracht werden, welches den Motor vor Tropfwasser und dem Eindringen von Fremdkörpern schützt.

TN-DN-MN	S1	T1
56	10	116
63	12	116
71	12	132
80	14	150
90	14	170
100	16	185
112	16	208

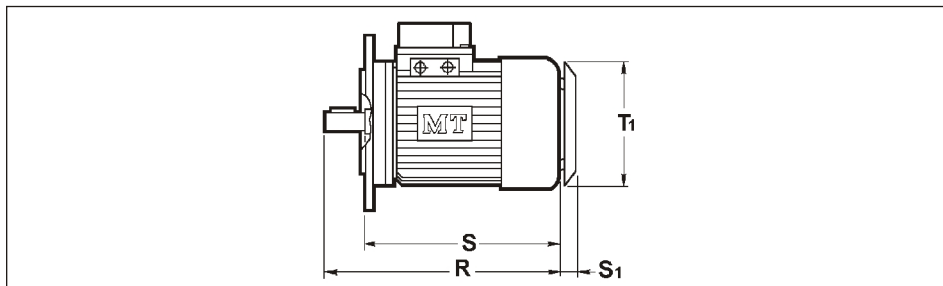

10.0 OPZIONI A RICHIESTA

10.0 OPTIONS UPON REQUEST

10.0 OPTIONAL AUF ANFRAGE

CONTROLLO DEL MOTO

MOTION CONTROL

BEWEGUNG PRÜFUNG

10.4 Encoder

I motori elettrici MT possono essere dotati, a richiesta, di un encoder incrementale serie EH80C/P.

Nelle tabelle seguenti sono indicate le caratteristiche tecniche e le variazioni dimensionali del motore su cui questo dispositivo è installato.

10.4 Encoder

The MT motors can be equipped with an incremental encoder series EH80C/P, upon request.

The following tables show the technical characteristics and the size changes of the motor on which such device is installed.

10.4 Encoder

Die Elektromotoren MT können auf Anfrage mit einem Inkremental-Encoder Serie EH80C/P ausgestattet werden. In den folgenden Tabellen sind die technischen Merkmale und die Abmessungsveränderungen des Motors, auf dem diese Vorrichtung installiert wurde, angegeben.

Caratteristiche tecniche / Technical characteristics / Technische Merkmale		
Risoluzione (impulsi/giro) Resolution (impulses/revolution) Auflösung (Impulse/Umdrehungen)	200 - 2048	non moltiplicati elettronicamente not geared up electronically nicht elektronisch übersetzt
Tensione di alimentazione Supply voltage Versorgungsspannung	5 Vdc / 8 - 24 Vdc+- 5%	N.B. Line Driver disponibile solo 5 Vdc N.B. Line driver is available only in 5 dcV version N.B. Line Driver ist nur mit 5Vdc Vdc+-5% verfügbar
Assorbimento a vuoto No-load absorption Leerbedarf	100 mA 200mA	per Mod. EH / for EH model / Für Modell EH per Mod. EF / For EF model / Für Modell EF
Configurazione elettronica in uscita Output electronic configuration Elektronische Ausgangskonfiguration	Line driver con driver AM26LS31 Line driver with driver AM26LS31 Line driver mit driver AM26LS31	NPN/NPN Open collector / push pull
Source and Sink current	40 mA 15 mA	per canale/ for channel / für Kanal per canale con / for channel with / für Kanal mit LINE DRIVER
Max. frequenza di utilizzo Max. working frequency Höchstbetriebsfrequenz	MAX 100 KHz	F= R.P.M. x Risoluzione 60 F= rpm x resolution 60 F= Umdreh./Min x Auflösung 60

TN-DN MN	S1
56	14
63	26
71	18
80	37
90	33
100	29
112	40
132	50
160	0

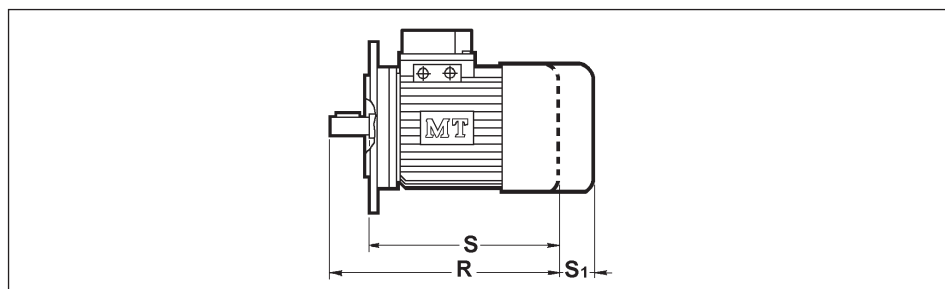

10.5 Cuscinetti sensorizzati

I motori elettrici MT dalla gr. 63 alla gr. 160 possono essere dotati di un cuscinetto con sensore magnetico in grado di registrare informazioni riguardanti il numero dei giri, la velocità, il senso di rotazione, la posizione relativa, le accelerazioni e decelerazioni. La tensione di alimentazione va da 5 a 24 V c.c.

Il numero di impulsi giro dipende dalla grandezza motore.

10.5 Sensor bearing unit

M.T. electric motors from size 63 to size 160 can be supplied with a sensor bearing unit which is able to record the number of revolutions, the speed, the direction of rotation, the relative position/counting, acceleration or deceleration.

The supply voltage is 5 to 24 Vdc. The number of impulses per revolution depends on the size of the motor.

10.5 Sensorlager

Die Elektromotoren M.T. der Größen 63 bis 160 können mit Lager mit Magnetsensor ausgestattet werden, wodurch die Möglichkeit besteht, Informationen zur Drehzahl, der Geschwindigkeit, dem Drehsinn, der relativen Position sowie der Beschleunigung und Verzögerung aufzuzeichnen.

Versorgungsspannung: 5 bis 24 V Gleichstrom.

Die Anzahl der Drehimpulse hängt von der Größe des Motors ab.

Grandezza Size Größe	Impulsi giro Impulses/revolution Drehimpulse
63 - 71	32
80 - 90	48
100 - 112	64
132 - 160	80

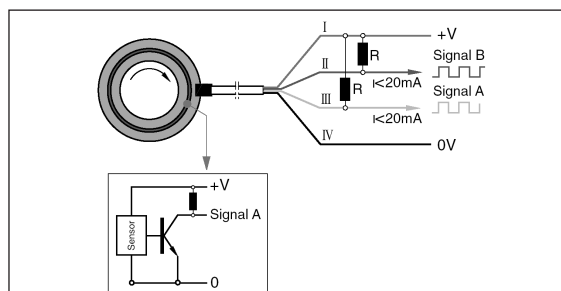







11.0 DATI TECNICI
11.0 TECHNICAL DATA
11.0 TECHNISCHE DATEN

Le pagine seguenti riportano i dati tecnici dei motori trifase, monofase e autofrenanti a singola e doppia polarità. La simbologia sottostante, richiamata sopra le tabelle, faciliterà la ricerca del tipo di motore desiderato.

The following pages list the technical data of threephase, single phase and brake motors with single and double polarity. The symbols heading our tables will facilitate the search the required motor.

Auf den folgenden Seiten sind die technischen Daten zu den Drehstrom- und Einphasenmotoren sowie zu Bremsmotoren, in ein und doppelpoliger Version, aufgeführt. Die nachstehenden Kurzbezeichnungen, die in den Tabellen aufgeführt werden, erleichtern die Suche des gewünschten Motortyps.

TN		Motori trifase standard <i>Standard Threephase motors</i> Standard Drehstrommotoren	2,4,6,8 poli <i>pole</i> polig
TF TFP TFS		Motori trifase autofrenanti <i>Threephase brake motors</i> Drehstrom- Bremsmotoren	
DN		Motori trifase a doppia polarità <i>Threephase two speed motors</i> Polumschaltbare - Drehstrommotoren	2/4, 4/6, 4/8 2/6, 2/8, 6/8 poli <i>pole</i> polig
DF DFP DFS		Motori trifase autofrenanti a doppia polarità <i>Threephase two speed brake motors</i> Polumschaltbare- Bremsmotoren	
MN XN		Motori monofase standard <i>Standard single phase motors</i> Standard Einphasenmotoren	2, 4, 6 poli <i>pole</i> polig
MF XF		Motori monofase autofrenanti standard <i>Standard single phase brake motors</i> Standard Einphasenbremsmotoren	

Simbologia

Grandezza	Denominazione	Unità di mis.
P_N	Potenza nominale	kW,HP
n	Velocità nominale	min ⁻¹
η	Rendimento	%
cosφ	Fattore di potenza	—
I_{sp}	Corrente di spunto	A
I_N	Corrente nominale	A
M_{sp}	Coppia di spunto	Nm
M_{MAX}	Coppia massima	Nm
M_N	Coppia nominale	Nm
C	Capacità condens.	μF
U	Tensione	V
J	Momento d'inerzia	Kgm ²

(nel caso di motore autofrenante, al valore J riportato nelle tabelle, dovrà essere sommato quello del freno a c.c. o a c.a. riportato nella pagina relativa).

Symbols

Size	Nomenclature	Unit of meas.
P_N	Nominal power	kW,HP
n	Nominal speed	min ⁻¹
η	Efficiency	%
cosφ	Power factor	—
I_{sp}	Starting current	A
I_N	Nominal current	A
M_{sp}	Starting torque	Nm
M_{MAX}	Max torque	Nm
M_N	Nominal torque	Nm
C	Capacitor capacity	μF
U	Tension	V
J	Moment of inertia	Kgm ²

(In case of brake motors add to J value reported in the tables, the d.c. or a.c. brake value reported in relevant page)

Kurzbezeichnungen

Größe	Bezeichnung	Maßeinheit
P_N	Nennleistung	kW,HP
n	Nenngeschwindigkeit	min ⁻¹
η	Wirkungsgrad	%
cosφ	Leistungsfaktor	—
I_{sp}	Anlaufstrom	A
I_N	Nennstrom	A
M_{sp}	Anlaufmoment	Nm
M_{MAX}	Maximalmoment	Nm
M_N	Nennmoment	Nm
C	Kondensatorskapazität	μF
U	Spannung	V
J	Trägheitsmoment	Kgm ²



(beim Bremsmotor muß zum J-Wert der jeweilige Wert der Gs oder Ws-Bremse dazugezählt werden).

TN

Motori trifase standard
Standard Threephase motors
Standard Drehstrommotoren
TF
TFP
TFS



Motori trifase autofrenanti
Threephase brake motors
Drehstrom- Bremsmotoren
2 poli/pole/polig 3000 rpm

Tipo Type Typ	P _N kW	P _N HP	n _n min ⁻¹	η %	cosφ	I _N (400V) A	$\frac{I_{sp}}{I_N}$	M _N Nm	$\frac{M_{sp}}{M_N}$	$\frac{M_{MAX}}{M_N}$	J Kgm ²	Kg (TN)	Kg (TF)
55 A	0.05	0.07	1320	55	0.71	0.30	2.8	0.20	2	2.2	0.00010	2.0	—
56 A	0.09	0.12	2730	59	0.71	0.45	2.8	0.32	2	2.2	0.00011	2.9	4.0
56 B	0.13	0.18	2730	60	0.73	0.50	3	0.45	2	2.3	0.00012	3	4.1
63 A	0.18	0.25	2740	64	0.76	0.60	3.5	0.63	2	2.2	0.00016	3.7	5.1
63 B	0.25	0.33	2750	65	0.78	0.85	3.5	0.85	2.1	2.3	0.00019	4.6	6.0
63 C	0.37	0.50	2770	68	0.80	1	3.8	1.30	2	2.4	0.00029	4.7	6.1
71 A	0.37	0.50	2800	70	0.81	1.1	4.3	1.29	2.2	2.5	0.00036	5.5	6.9
71 B	0.55	0.75	2820	73	0.81	1.4	4.5	1.85	2.2	2.5	0.00047	6.5	7.9
71 C	0.75	1	2820	78	0.82	1.7	4.5	2.58	2.2	2.6	0.00057	7.2	8.6
80 A	0.75	1	2830	77	0.83	1.8	4.8	2.58	2.3	2.7	0.00085	8.7	10.6
80 B	1.1	1.5	2830	79	0.84	2.5	5	3.78	2.3	2.7	0.00105	10.8	12.7
90 S	1.5	2	2840	79	0.83	3.6	5.5	5.1	2.5	2.8	0.00145	12.9	16.0
90 L	2.2	3	2850	81	0.87	4.8	5.6	7.5	2.5	3.0	0.00191	14.8	17.9
100 A	3	4	2870	83	0.88	6.4	5.8	10	2.4	3.0	0.00299	22	27.6
100 B	4	5.5	2880	84	0.88	8.5	6.2	13.4	2.5	3.2	0.00407	27	32.6
112 A	4	5.5	2880	84	0.88	9.3	6.8	13.4	2.5	3.2	0.00520	29	38.7
112 B	5.5	7.5	2880	84	0.84	12.0	6.8	18.5	2.5	3.2	0.00700	32	41.7
132 SA	5.5	7.5	2860	85	0.88	11.5	6.5	18.3	2.4	3.0	0.01080	44	61
132 SB	7.5	10	2870	85	0.88	16.5	6.8	25	2.4	3.2	0.01300	50	67
132 MC	9.2	12.5	2880	85	0.88	19	6.8	30.6	2.4	3.2	0.01639	59	76
132 MD	11	15	2880	85	0.82	23	6.7	36.5	2.4	3.2	0.01873	65	82
160 MA	11	15	2920	88	0.87	21	7	36	2	2.2	0.03300	115	—
160 MB	15	20	2920	89	0.87	28	7	49	2	2.2	0.04500	125	—
160 L	18.5	25	2920	89	0.87	34	7	61.0	2	2.2	0.05400	145	—
180 M	22	30	2940	89	0.89	40	7	72.0	2	2.2	0.07300	173	—
200 LA	30	40	2940	90	0.89	54	7	98.0	2	2.2	0.12000	232	—
200 LB	37	50	2950	91	0.89	66	7	120	2	2.2	0.15000	250	—
225 M	45	60	2950	92	0.89	80	7	146	2	2.2	0.22000	312	—
250 M	55	75	2970	92	0.89	98	7	178	2	2.2	0.36000	387	—
280 S	75	100	2970	92	0.89	133	7	241	2	2.2	0.61000	515	—
280 M	90	125	2970	92	0.89	159	7	290	2	2.2	0.70000	566	—
315 S	110	150	2970	93	0.89	192	7	354	1.8	2.2	1.46000	922	—
315 MA	132	175	2980	93	0.89	229	7	423	1.8	2.2	1.70000	1010	—
315 MB	150	200	2980	94	0.89	276	7	481	1.8	2.2	2.00000	1085	—
315 LA	160	220	2980	94	0.89	288	6.8	513	1.8	2.2	2.00000	1200	—
315 LB	175	238	2980	94	0.89	304	6.8	561	1.8	2.2	2.08000	1250	—
315 LC	185	250	2980	94	0.89	321	6.8	593	1.8	2.2	2.20000	1250	—
315 LD	200	270	2980	94	0.89	347	6.8	641	1.8	2.2	2.20000	1250	—
355 MA	220	300	2980	95	0.89	377	6.8	705	1.2	2.2	2.60000	1750	—
355 MB	250	340	2981	95	0.90	422	6.8	801	1.2	2.2	2.97000	1770	—
355 LA	280	280	2982	95	0.90	472	6.8	897	1.2	2.2	3.77000	1830	—
355 LB	315	430	2981	96	0.90	530	6.8	1010	1.2	2.2	4.25000	1900	—

TN		Motori trifase standard <i>Standard Threephase motors</i> Standard Drehstrommotoren
TF TFP TFS		Motori trifase autofrenanti <i>Threephase brake motors</i> Drehstrom- Bremsmotoren

4 poli/pole/polig 1500 rpm

Tipo Type Typ	P _N kW	P _N HP	n _n min ⁻¹	η %	cosφ	I _N (400V) A	$\frac{I_{sp}}{I_N}$	M _N Nm	$\frac{M_{sp}}{M_N}$	$\frac{M_{MAX}}{M_N}$	J Kgm ²	Kg (TN)	Kg (TF)
55 A	0.05	0.07	1320	50	0.65	0.36	2	0.42	1.7	2	0.00010	2.0	—
56 B	0.09	0.12	1340	56	0.65	0.40	2.3	0.65	1.8	2	0.00018	2.9	4.0
63 A	0.13	0.18	1360	60	0.68	0.60	2.4	0.93	2	2.2	0.00025	3.7	5.1
63 B	0.18	0.25	1380	62	0.69	0.70	2.6	1.29	2.2	2.3	0.00029	4.5	5.9
71 A	0.25	0.33	1400	63	0.71	0.90	3	1.7	2.2	2.3	0.00074	5.4	6.8
71 B	0.37	0.50	1400	68	0.71	1.2	3.2	2.52	2.3	2.6	0.00096	6.4	7.8
71 C	0.55	0.75	1400	72	0.75	1.5	3.9	3.75	2.4	2.5	0.00117	7	8.4
80 A	0.55	0.75	1410	74	0.78	1.6	3.9	3.80	2.4	2.6	0.00191	8.5	10.4
80 B	0.75	1	1410	74	0.78	2.1	4	5	2.2	2.4	0.00254	10.5	12.4
80C	0.95	1.3	1410	74	0.78	2.8	4	6.56	2.3	2.6	0.00285	11.5	13.4
90 S	1.1	1.5	1410	74	0.78	3	4.3	7.5	2.2	2.4	0.00242	12.5	15.6
90 L	1.5	2	1420	78	0.80	3.8	4.6	10	2.3	2.6	0.00321	14	17.1
90 LB	1.8	2.5	1420	78	0.80	4.6	4.7	12.1	2.3	2.6	0.00400	16	19.1
100 A	2.2	3	1430	80	0.82	5.4	4.8	15	2.2	2.5	0.00520	20	25.6
100 B	3	4	1430	81	0.82	7	5	20	2.3	2.6	0.00668	24	29.6
112 A	4	5.5	1430	83	0.83	9	5.2	27	2.4	2.7	0.01052	29	38.7
112 B	5.5	7.5	1450	83	0.83	12.5	5.5	36.2	2.4	2.2	0.01320	32	41.7
132 SA	5.5	7.5	1430	83	0.83	12	6	37	2.5	2.8	0.01940	42	59
132 MB	7.5	10	1430	83	0.83	16	6.1	50	2.5	2.8	0.02688	53	70
132 MC	9.2	12.5	1430	85	0.85	18	6.1	62	2.5	2.8	0.03059	58	75
132 MD	11	15	1430	85	0.85	22.5	6	75.0	2.0	2.5	0.03632	69	81
160 M	11	15	1450	89	0.86	21	7	72.5	2.0	2.3	0.06800	122	—
160 L	15	20	1450	89	0.86	29	7	99	2.2	2.3	0.09200	142	—
180 M	18.5	25	1470	91	0.86	34	7	120	2.0	2.2	0.12800	174	—
180 L	22	30	1470	92	0.86	41	7	143	2.0	2.2	0.15200	192	—
200 L	30	40	1470	92	0.87	54	7	195	2.0	2.2	0.24900	253	—
225 S	37	50	1480	92	0.87	67	7	239	1.9	2.2	0.13920	294	—
225 M	45	60	1480	92	0.88	80	7	291	1.9	2.2	0.47400	327	—
250 M	55	75	1480	93	0.88	98	7	355	2.0	2.2	0.73600	381	—
280 S	75	100	1480	93	0.88	133	7	484	1.9	2.2	1.22000	535	—
280 M	90	125	1480	94	0.89	156	7	591	1.9	2.2	1.46000	634	—
315 S	110	150	1487	96	0.89	190	7	707	1.8	2.2	2.12000	912	—
315 MA	132	180	1487	94	0.89	227	7	848	1.8	2.2	2.54000	1048	—
315 MB	150	200	1487	95	0.89	274	7	964	1.8	2.2	2.97000	1105	—
315 LA	160	220	1486	95	0.87	288	6.8	1028	1.8	2.2	2.97000	1200	—
315 LB	185	250	1487	95	0.89	317	6.8	1189	1.8	2.2	3.18000	1205	—
315 LC	200	270	1487	95	0.89	343	6.8	1285	1.8	2.2	3.25000	1210	—
355 MA	220	300	1488	95	0.87	386	6.8	1413	1.3	2.2	5.70000	1720	—
355 MB	250	340	1489	95	0.87	437	6.8	1604	1.3	2.2	6.48000	1800	—
355 LA	280	380	1489	95	0.87	488	6.8	1797	1.3	2.2	7.40000	1860	—
355 LB	315	430	1488	96	0.87	547	6.8	2023	1.3	2.2	8.20000	1940	—



TN		Motori trifase standard <i>Standard Threephase motors</i> Standard Drehstrommotoren
TF TFP TFS		Motori trifase autofrenanti <i>Threephase brake motors</i> Drehstrom- Bremsmotoren

6 poli /pole/polig 1000 rpm

Tipo Type Typ	P _N kW	P _N HP	n _n min ⁻¹	η %	cosφ	I _N (400V) A	$\frac{I_{sp}}{I_N}$	M _N Nm	$\frac{M_{sp}}{M_N}$	$\frac{M_{MAX}}{M_N}$	J Kgm ²	Kg (TN)	Kg (TF)
56 C	0.06	0.08	840	48	0.59	0.4	2.2	0.68	1.8	2	0.00018	3	4.1
63 A	0.09	0.12	850	52	0.60	0.5	2.2	1	1.8	2	0.00029	3.8	5.2
63 B	0.12	0.16	870	54	0.60	0.6	2.3	1.3	1.8	2	0.00034	4.6	6.0
71 A	0.18	0.25	880	56	0.62	0.8	2.5	1.95	1.8	2	0.00074	5.5	6.9
71 B	0.25	0.33	900	60	0.65	1	2.9	2.65	1.9	2.2	0.00096	6.5	7.9
80 A	0.37	0.50	910	62	0.66	1.27	3.2	3.88	1.9	2.2	0.00191	8.5	10.4
80 B	0.55	0.75	910	66	0.70	1.8	3.5	5.77	2	2.3	0.00254	10.5	12.4
90 S	0.75	1	920	68	0.70	2.4	3.5	7.79	1.8	2	0.00242	12.5	15.6
90 L	1.1	1.5	920	70	0.70	3.4	3.5	11.4	1.8	2	0.00398	14	17.1
100 A	1.5	2	940	75	0.72	4.2	4	15.2	1.8	2	0.00519	24	29.6
112 A	2.2	3	940	80	0.77	5.7	5	22.4	1.9	2.4	0.00720	34	43.7
132 SA	3	4	940	82	0.78	7.6	5.4	30.5	2	2.5	0.01940	44	61
132 MB	4	5.5	940	82	0.80	9	5.3	40.5	2	2.5	0.02688	55	72
132 MC	5.5	7.5	940	82	0.80	12.7	5.3	57	2	2.5	0.03430	60	77
160 M	7.5	10	960	87	0.77	16.5	6.5	75	2.0	2.3	0.09300	110	—
160 L	11	15	960	88	0.79	23	6.5	110	2.0	2.3	0.12700	130	—
180 L	15	20	970	90	0.81	30	6.5	148	1.8	2.0	0.19200	1892	—
200 LA	18.5	25	970	90	0.83	36	6.5	182	1.8	2.0	0.28100	220	—
200 LB	22	30	970	90	0.83	43	6.5	217	1.8	2.0	0.32400	246	—
225 M	30	40	980	90	0.85	57	6.5	293	1.7	2.0	0.73600	294	—
250 M	37	50	980	91	0.86	69	6.5	361	1.8	2.0	1.01000	395	—
280 S	45	60	980	92	0.87	81	6.5	439	1.8	2.0	1.48000	505	—
280 M	55	75	980	92	0.87	99	6.5	536	1.8	2.0	1.78000	566	—
315 S	75	100	988	93	0.87	134	6.5	725	1.6	2.0	2.63000	850	—
315 MA	90	125	988	93	0.87	161	6.5	870	1.6	2.0	3.08000	1050	—
315 MB	110	150	988	94	0.87	195	6.5	1064	1.6	2.0	3.63000	1110	—
315 MC	132	180	989	96	0.87	234	6.7	1275	1.6	2.0	4.17000	1120	—
355 MA	160	220	990	94	0.86	285	6.7	1544	1.3	2.0	10.7000	1590	—
355 MB	185	250	990	95	0.86	234	6.7	1785	1.3	2.0	11.8000	1680	—
355 MC	200	270	990	95	0.86	355	6.7	1930	1.3	2.0	12.7000	1750	—

8 poli /pole/polig 750 rpm

Tipo Type Typ	P _N kW	P _N HP	n _n min ⁻¹	η %	cosφ	I _N (400V) A	$\frac{I_{sp}}{I_N}$	M _N Nm	$\frac{M_{sp}}{M_N}$	$\frac{M_{MAX}}{M_N}$	J Kgm ²	Kg (TN)	Kg (TF)
63 B	0.07	0.10	660	42	0.56	0.6	1.3	1	1.8	2	0.00029	4.5	5.9
71 B	0.12	0.16	670	46	0.60	0.8	2	1.72	1.8	2	0.00096	6.5	7.9
80 A	0.18	0.25	690	50	0.60	0.9	2.5	2.5	1.8	2	0.00191	8.4	10.3
80 B	0.25	0.33	700	50	0.60	1	2.5	3.4	1.8	2	0.00254	10.4	12.3
90 S	0.37	0.5	700	58	0.60	1.6	3	5	2	2.2	0.00242	12.3	15.4
90 L	0.55	0.75	700	62	0.62	2.2	3.2	7.5	2	2.2	0.00320	13.8	16.9
100 A	0.75	1	700	70	0.64	2.6	3.5	10.4	2	2.4	0.00519	23	28.6
100 B	1.1	1.5	700	72	0.64	3.6	3.5	15.2	2	2.4	0.00668	30	35.6
112 A	1.5	2	700	74	0.66	4.7	4	20.7	2.1	2.4	0.01220	33	42.7
132 SA	2.2	3	700	75	0.65	7	4.1	30	2.2	2.4	0.01940	44	61
132 MB	3	4	700	77	0.65	9	4.3	41	2.2	2.4	0.03430	55	72
160 MA	4	5.5	710	80	0.70	9.8	4.5	54	1.8	2	0.07900	110	130
160 MB	5.5	7.5	720	84	0.74	11.6	5	73	1.8	2	0.10500	122	149
160 L	7.5	10	720	85	0.75	16.8	5	100	1.8	2	0.14300	144	169

DN		Motori trifase a doppia polarità Threephase two speed motors Polumschaltbare - Drehstrommotoren
DF DFP DFS		Motori trifase autofrenanti a doppia polarità Threephase two speed brake motors Polumschaltbare - Bremsmotoren

2/4 poli/pole/polig 3000/1500 rpm Avvolgimento unico / Single winding / Einfachwicklung



Typo Type Typ	P _N kW	P _N HP	n _n min ⁻¹	I _N (400V) A	$\frac{I_{sp}}{I_N}$	M _N Nm	$\frac{M_{sp}}{M_N}$	$\frac{M_{MAX}}{M_N}$	J Kgm ²	Kg (DN)	Kg (DF)
63 A	0.18/0.12	0.25/0.16	2750/1350	0.75/0.5	3/2.5	0.65/0.85	1.3/1.3	1.4/1.5	0.00025	3.7	5.1
63 B	0.22/0.15	0.30/0.20	2760/1360	0.83/0.6	3/2.5	0.76/1	1.3/1.3	1.4/1.5	0.00029	4.5	5.9
71 A	0.30/0.20	0.40/0.28	2780/1400	1.2/1	3/3	1/1.4	1.5/1.3	1.6/1.8	0.00074	5.4	6.8
71 B	0.44/0.30	0.60/0.40	2780/1400	1.6/1.3	3/3	1.5/2	1.5/1.4	1.6/1.8	0.00096	6.4	7.8
80 A	0.60/0.45	0.8/0.6	2780/1400	2/1.6	3.5/3.5	2/3	1.5/1.3	1.8/1.8	0.00191	8.4	10.3
80 B	0.80/0.60	1.1/0.8	2800/1400	2.5/1.9	3.5/3.5	2.7/4	1.6/1.3	1.8/1.8	0.00254	10.5	12.4
90 L	1.8/1.2	2.5/1.7	2830/1420	4.5/3.1	5/4.5	6/8	2.1/2	2.2/2	0.00321	14	17.1
90 LL	2.2/1.5	3/2	2830/1420	5.5/3.7	5/4.5	7.5/10	2.1/2	2.4/2.2	0.00398	16	19.1
100 A	2.5/1.8	3.4/2.5	2830/1420	6.2/4.5	5/4.5	8.3/12	2.3/1.9	2.6/2	0.00519	20	25.6
100 B	3.3/2.5	4.4/3.4	2850/1430	8.1/5.9	6/5	11/16.7	2.4/2.2	2.8/2.4	0.00668	24	29.6
112 A	4.5/3.3	6/4.5	2850/1430	9.8/7	6/5	15/22	2.4/2.3	3/2.4	0.01223	34	43.7
132 S	5.5/4	7.5/5.5	2910/1450	13/9.5	6.5/5.5	18.5/26.5	2.4/2.3	3/2.5	0.01080	44	60
132 M	7.5/6.2	10/8.5	2910/1450	16.5/13.5	7/6	25/42	2.5/2.8	3/2.5	0.01639	59	75
160 M	11/9	15/12.2	2940/1460	23/19.5	7/6	35.7/52.9	2.5/2.6	3/2.5	0.06200	122	149
160 L	17/13	23/17.5	2930/1460	33/26	7.5/6.3	55.4/85	2.4/2.5	3/2.5	0.09200	142	169

4/6 poli/pole/polig 1500/1000 rpm Doppio avvolgimento / Double bobinage / Doppelwicklung

71 B	0.30/0.22	0.40/0.30	1380/890	1/0.9	3.5/2	2/2.3	1.3/1.3	2/1.8	0.00057	6.5	7.9
80 A	0.37/0.26	0.50/0.35	1410/900	1.4/1.2	3.5/2.5	2.5/2.7	1.3/1.4	1.9/2.1	0.00191	8.5	10.4
80 B	0.55/0.45	0.75/0.60	1420/920	2/1.8	3.5/2.5	3.7/4.6	1.5/1.8	2.1/2.3	0.00254	10.5	12.4
90 S	0.75/0.5	1/0.7	1420/920	2.4/2.1	4/2.5	5/5.2	1.4/1.3	2.1/2	0.00242	12.5	15.6
90 L	1.1/0.75	1.5/1	1470/900	3.9/3.7	4.2/2.5	7.3/7.9	1.4/1.4	2.1/2.1	0.00321	14	17.1
100 A	1.3/0.9	1.8/1.2	1430/920	4/3.8	4.5/3	8.6/9.3	1.4/1.4	2.1/2.2	0.00519	21	26.6
100 B	1.5/1.1	2/1.5	1430/930	5.4/4.8	4.5/3	10/11.2	1.4/1.5	2.2/2.3	0.00668	24	29.6
112 A	2.2/1.5	3/2	1430/930	6/5.8	4.5/3.5	14.7/15.4	1.4/1.3	1.7/1.6	0.01052	34	43.7
132 S	2.5/1.8	3.5/2.5	1420/930	6.5/6	5.5/4.8	17/18.8	1.6/1.5	1.8/1.6	0.01080	44	60
132 M	4/3	5.5/4	1440/930	8.5/6.9	6.5/5.5	27/31.4	1.8/1.7	2/1.9	0.01639	59	75
160 M	6.5/4.5	8.8/6	1450/940	15/11.6	5/4.6	43/45	1.8/1.7	2/1.9	0.06200	122	149
160 L	9.5/6.5	13/8.8	1450/940	21/17	5.4/4.4	62/66	2/1.8	2/1.9	0.09200	152	179

4/8 poli/pole/polig 1500/750 rpm Avvolgimento unico / Single winding / Einfachwicklung

63 B	0.09/0.04	0.12/0.06	1360/660	0.6/0.55	3.5/2	0.6/0.57	1.3/1.3	1.9/1.8	0.00029	4.6	6.0
71 B	0.15/0.09	0.20/0.12	1390/690	0.7/0.65	3.5/2	1/1.2	1.3/1.3	1.9/1.8	0.00096	6.5	7.9
80 A	0.29/0.18	0.40/0.25	1410/700	1.3/1.1	3.5/2.5	1.9/2.4	1.5/1.8	2/1.8	0.00191	8.5	10.4
80 B	0.37/0.22	0.5/0.30	1420/700	1.8/1.7	3.5/2.5	2.4/3	1.5/1.8	2/1.8	0.00254	10.5	12.4
90 S	0.6/0.26	0.8/0.35	1430/700	1.9/1.8	4/2.5	4/3.5	1.4/1.3	2/1.8	0.00242	12.5	15.6
90 L	1/0.5	1.3/0.7	1430/700	2.6/2.5	4.5/2.5	6.8/6.8	1.4/1.4	2/1.8	0.00321	14	17.1
100 B	1.5/0.75	2/1	1430/700	3.8/3.6	4.5/3	10/10	1.4/1.5	2/1.8	0.00668	24	29.6
112 A	2.2/1.3	3/1.8	1410/700	4.7/4.3	4.5/3.4	15.2/17.7	1.6/1.5	1.9/1.9	0.01223	34	44
132 S	3.1/1.7	4.2/2.3	1420/710	7/5.9	4.7/3.8	21.2/23.3	1.8/1.8	2/2.1	0.01080	44	60
132 M	5/2.8	6.8/3.8	1440/720	13/8.2	5.2/4.3	33.7/3.7	1.8/1.8	2.2/2.3	0.01639	59	75
160 M	6/4	8/5.5	1440/720	13/9.2	5/4.6	39.8/53	1.6/1.5	2/2	0.06200	122	149
160 L	11/7.5	15/10	1440/720	22/17.5	5.2/4.7	43/100	1.7/1.5	2/2	0.09200	142	169

DN		Motori trifase a doppia polarità Threephase two speed motors Polumschaltbare - Drehstrommotoren
DF DFP DFS		Motori trifase autofrenanti a doppia polarità Threephase two speed brake motors Polumschaltbare - Bremsmotoren

2/6 poli/pole/polig 3000/1000 rpm Doppio avvolgimento / Double bobinage / Doppelwicklung

Tipo Type Typ	P _N kW	P _N HP	n _n min ⁻¹	I _N (400V) A	$\frac{I_{sp}}{I_N}$	M _N Nm	$\frac{M_{sp}}{M_N}$	$\frac{M_{MAX}}{M_N}$	J Kgm ²	Kg (DN)	Kg (DF)
71 C	0.25/0.15	0.33/0.20	2780/850	1.15/0.9	4/2	0.85/1.7	1.6/1.3	2/1.8	0.00117	7	8.4
80 C	0.75/0.37	1/0.50	2800/880	2.7/1.8	4.2/2.5	2.5/4	1.8/1.8	2.4/2.3	0.00285	11.5	13.4
90 S	1.1/0.55	1.5/0.75	2800/900	3.3/1.6	4.5/2.5	3.75/5.8	1.6/1.5	2.4/2.4	0.00242	12.5	15.6
90 LB	1.5/0.75	2/1	2800/910	4.3/3.7	4.8/2.8	5.2/7.9	1.6/1.5	2.3/2.4	0.00321	14	17.1
100 B	2.2/1.1	3/1.5	2820/910	5.5/4.8	5/3	7.5/11.5	1.8/1.5	2.4/2.3	0.00668	24	29.6
112 B	3/1.5	4/2	2820/920	6.9/5.8	5.5/3.5	10.2/15.6	1.9/1.3	2.5/1.8	0.01052	29	38.7
132 S	4/1.7	5.5/2.3	2840/930	9/4.3	5/4	13.3/13	2/1.8	2.3/1.8	0.01940	44	60
132 M	5.5/2	7.5/2.7	2850/930	12/6	5.5/4.6	18.2/20	2.2/1.8	2.3/1.8	0.03430	60	77
160 M	7.5/2.5	10.2/3.4	2880/950	16/7	6/4.7	25/25	2/2	1.8/1.8	0.06200	122	149
160 L	11/3.7	15/5	2900/960	25/11	6.2/4.8	36/36.8	2/2	1.8/1.8	0.09200	142	169

2/8 poli/pole/polig 3000/750 rpm Doppio avvolgimento / Double bobinage / Doppelwicklung

63 C	0.18/0.06	0.25/0.08	2750/640	0.90/0.50	3.4/2.3	0.62/0.88	1.6/1.9	1.8/1.6	0.00034	4.8	6.2
71 C	0.30/0.09	0.40/0.12	2770/660	1.15/0.65	4/2.3	1/1.35	1.6/2	2/1.6	0.00117	7	0.4
80 B	0.55/0.11	0.75/0.15	2800/680	2/0.9	4/2.4	1.9/1.65	1.8/2	2.2/1.8	0.00254	10.5	12.4
80 C	0.6/0.13	0.85/0.18	2800/680	2.6/1.2	4.2/2.4	2.1/1.85	1.8/2	2.4/2.1	0.00225	11.5	13.4
90 S	1.1/0.3	1.5/0.4	2830/700	3.3/1.5	4.5/2.5	3.7/4.1	1.6/1.8	2.4/2	0.00242	12.5	15.6
90 L	1.5/0.4	2/0.55	2850/700	4/1.6	4.5/2.5	5.1/5.5	1.6/1.8	2.4/2.1	0.00321	14	17.1
90 LB	1.8/0.5	2.5/0.65	2870/700	4.3/2	4.8/2.7	6/6.9	1.6/1.8	2/1.6	0.00400	16	19.1
100 B	2.2/0.6	3/0.8	2900/710	5.5/3	5/2.9	7.3/8.1	1.8/1.9	2/1.8	0.00668	24	29.6
112 A	3/0.75	4/1	2920/710	6.9/3.4	5.5/2.9	9.8/10.1	1.9/2	2.2/2	0.01052	29	38.7
132 S	4/1	5.5/1.3	2880/710	8.6/4.5	5/3.8	13/13.5	1.9/1.8	2.2/2	0.02688	44	60
132 M	5.5/1.4	7.5/1.9	2890/700	11.8/6	5.5/3/8	18.2/19.1	1.9/1.8	2.2/2	0.03430	60	77
160 M	7.5/1.8	10/2.5	2900/730	16.5/7	6/3.4	24.7/23.5	2/1.7	2/2	0.06200	122	149
160 L	11/2.5	15/3.4	2900/730	22/9	6.2/4	36.2/32.7	1.9/1.6	2.1/2	0.09200	142	169

6/8 poli/pole/polig 1000/750 rpm Doppio avvolgimento / Double bobinage / Doppelwicklung

71 C	0.15/0.09	0.20/0.12	850/660	0.9/0.65	2/1.8	1.7/1.35	1.3/2	1.8/1.6	0.00117	7	8.4
80 C	0.30/0.13	0.40/0.18	880/680	1.8/1.2	2.5/2.2	4/1.85	1.8/2	2.3/2.1	0.00285	11.5	13.4
90 S	0.37/0.25	0.5/0.33	900/700	1.7/1.4	2.5/2.5	5.8/4.1	1.5/2	2.4/2.1	0.00242	12.5	15.6
90 LB	0.60/0.37	0.8/0.5	910/870	2.7/1.8	2.8/2.7	7.9/6.9	1.3/1.8	2.4/1.6	0.00400	14.5	17.6
100 B	1/0.50	1.30/0.70	910/710	4/2.5	3/2.9	11.5/8.1	1.5/1.8	2.3/1.8	0.00668	24	29.6
112 B	1.5/0.75	2/1	920/710	5/3.3	3.5/2.9	15.6/10.1	1.8/2	2.2/1.8	0.01052	29	38.6
132 S	1.8/1	2.5/1.3	940/720	6.6/5.1	4.5/4	18.3/13.3	1.8/1.7	2.2/1.8	0.02688	44	60
132 M	3/2.2	4/3	940/720	9.3/7.4	4.5/4	30.5/21.2	1.7/1.6	2.3/1.8	0.03430	60	77
160 M	5.5/4	7.5/5.5	970/720	12.5/9.5	5.2/4.3	54/53	1.6/1.6	2.2/1.8	0.06200	122	149
160 L	7.5/5.5	10/7.5	970/720	15.5/14.5	5.4/4.4	74/73	1.7/1.6	2.2/1.8	0.09200	142	169

**MN
XN**

Motori monofase standard
Standard single phase motors
Standard Einphasenmotoren
**MF
XF**

Motori monofase autofrenanti standard
Standard single phase brake motors
Standard Einphasenbremsmotoren
2 poli/pole/polig 3000 rpm

Tipo Type Typ	kW	HP	n_n min ⁻¹	%	cos	I_N (230V) A	$\frac{I_{sp}}{I_N}$	M_N Nm	$\frac{M_{sp}}{M_N}$	$\frac{M_{MAX}}{M_N}$	C μF	J Kgm ²	Kg (MN)	Kg (MF)
56 A	0.09	0.12	2740	54	0.90	0.85	2.4	0.28	0.58	1.4	6.3	0.00011	3	4.1
63 B	0.18	0.25	2750	54	0.92	1.5	2.5	0.62	0.62	1.6	8	0.00025	4.7	6.2
63 C	0.25	0.33	2750	56	0.94	2.2	2.5	0.85	0.66	1.6	10	0.00034	4.8	6.3
71 B	0.37	0.5	2780	60	0.94	3.2	3	1.28	0.70	1.8	12.5	0.00047	6.7	8.2
71 C	0.55	0.75	2800	64	0.96	4	3.5	1.9	0.70	1.8	16	0.00057	7.4	8.9
80 B	0.75	1	2820	70	0.96	5.5	3.5	2.5	0.74	1.8	20	0.00105	11	13.2
90 S	1.1	1.5	2830	70	0.98	8.5	3.6	3.8	0.76	1.9	30	0.00172	13.2	16.3
90 L	1.5	2	2830	74	0.98	11.5	3.6	5.1	0.76	1.9	35	0.00191	15.1	18.2
100 A	2.2	3	2830	76	0.98	13.2	4	7.4	0.70	1.9	60	0.00299	23	28.3

4 poli/pole/polig 1500 rpm

Tipo Type Typ	kW	HP	n_n min ⁻¹	%	cos	I_N (230V) A	$\frac{I_{sp}}{I_N}$	M_N Nm	$\frac{M_{sp}}{M_N}$	$\frac{M_{MAX}}{M_N}$	C μF	J Kgm ²	Kg (MN)	Kg (MF)
56 B	0.09	0.12	1340	54	0.90	0.95	1.6	0.65	0.90	1.4	6.3	0.00018	3.1	4.2
63 B	0.12	0.16	1370	58	0.90	1.2	2.5	0.84	0.74	1.6	6.3	0.00025	4.6	6.1
63 C	0.18	0.25	1370	58	0.92	1.6	2.5	1.3	0.78	1.6	8	0.00034	4.8	6.3
71 B	0.25	0.33	1380	58	0.94	2.3	2.5	1.8	0.78	1.6	14	0.00096	6.6	8.1
71 C	0.37	0.5	1380	58	0.94	3	2.8	2.5	0.82	1.6	16	0.00117	7.2	8.7
80 B	0.55	0.75	1400	62	0.94	4.2	3	3.7	0.75	1.8	20	0.00254	10.8	13
80C	0.75	1	1400	66	0.94	6.5	3	5.1	0.73	1.8	25	0.00285	11.8	14
80 D	0.88	1.2	1400	66	0.94	7	3	6	0.70	1.8	30	0.00316	12.3	14.5
90 S	1.1	1.5	1410	68	0.96	8.5	3.2	7.5	0.70	1.8	30	0.00320	12.9	16.0
90 L	1.5	2	1410	68	0.96	9.3	3.2	10.2	0.65	1.8	35	0.00398	14.5	17.6
100 A	1.8	2.5	1420	70	0.96	12.5	3.2	12.1	0.60	1.8	40	0.00520	21	26.5
100 B	2.2	3	1420	70	0.96	15.0	3.2	14.8	0.60	1.8	50	0.00668	25	30.5

6 poli/pole/polig 1000 rpm

Tipo Type Typ	kW	HP	n_n min ⁻¹	%	cos	I_N (230V) A	$\frac{I_{sp}}{I_N}$	M_N Nm	$\frac{M_{sp}}{M_N}$	$\frac{M_{MAX}}{M_N}$	C μF	J Kgm ²	Kg (MN)	Kg (MF)
63	0.12	0.16	870	50	0.90	1.5	2.5	1.12	0.68	1.4	8	0.00034	4.8	6.3
71 B	0.18	0.25	900	52	0.92	2	2.5	1.9	0.70	1.4	10	0.00117	6.6	8.1
80 A	0.37	0.5	920	58	0.94	3.5	2.7	3.8	0.72	1.5	16	0.00254	8.8	11
90 S	0.55	0.75	920	62	0.96	4.6	3	5.7	0.76	1.6	25	0.00242	12.9	16.0
90L	0.75	1	930	65	0.96	6.1	3	7.8	0.76	1.6	30	0.00321	14.5	17.6
100 A	1.1	1.5	930	66	0.96	9	3.2	11.3	0.70	1.8	40	0.00662	21	26.5
100 B	1.5	2	930	66	0.96	13.5	3.2	15.4	0.70	1.8	50	0.00812	25	30.5

12.0 DIMENSIONI
DIMENSIONS
ABMESSUNGEN

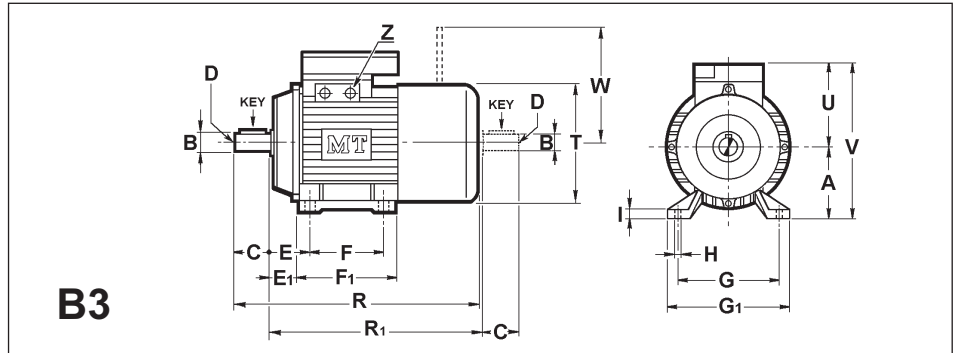
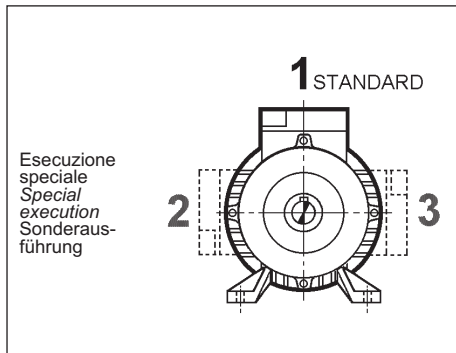
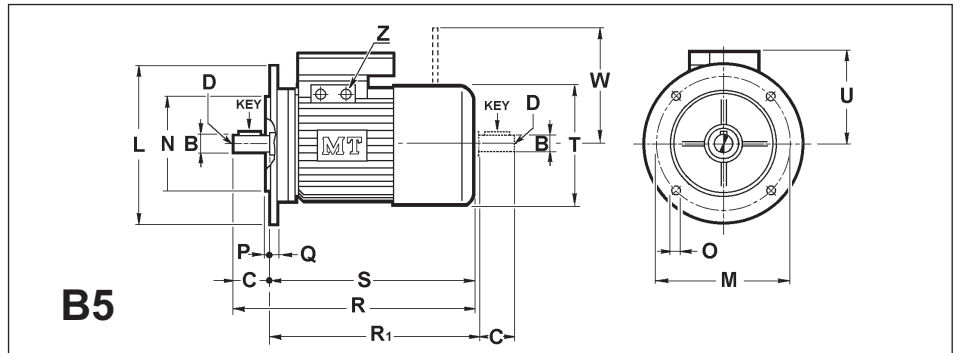
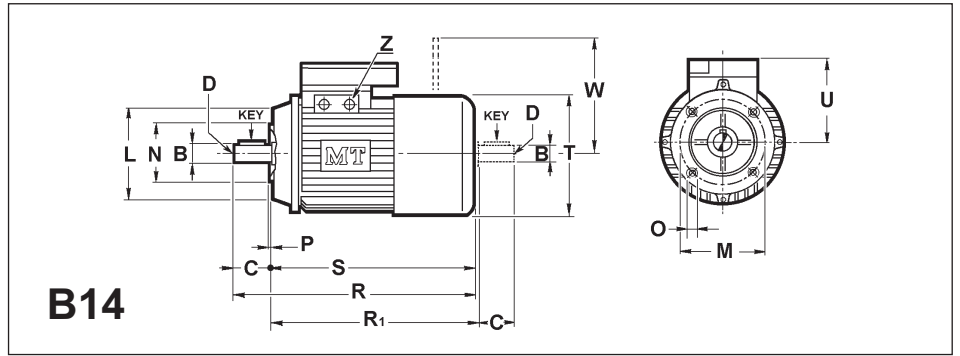
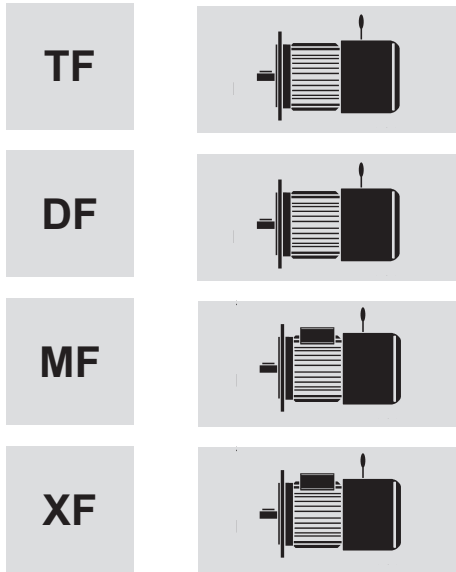

	B3										B14					
	A	E	E1	F	F1	G	G1	H	I	V	L	M	N	O	P	S
56	56	36	26	71	90	90	108	6	9	156	80	65	50	M5	2.5	208
63	63	40	28	80	105	100	120	7	10	168	90	75	60	M5	2.5	235
71	71	45	36	90	108	112	136	7	11	185	105	85	70	M6	2.5	270
80	80	50	38	100	125	125	154	9.5	11	206	120	100	80	M6	3	295
90S	90	56	41	100	130	140	174	9.5	13	223	140	115	95	M8	3	315
90L	90	56	41	125	155	140	174	9.5	13	223	140	115	95	M8	3	340
100	100	63	46	140	175	160	192	12	14	242	160	130	110	M8	3.5	381
112	112	70	53	140	180	190	234	12	14	265	160	130	110	M8	3.5	410
132 S	132	89	60	140	180	216	256	12	16	310	200	165	130	M10	4	472
132 M	132	89	60	178	218	216	256	12	16	310	200	165	130	M10	4	510
160 M	160	108	83	210	260	254	318	15	22	400	—	—	—	—	—	—
160 L	160	108	83	254	304	254	318	15	22	400	—	—	—	—	—	—

	B3 - B5 -B14										B5							
	B	C	D	R	R1	T	U	Z	Key	W (c.a.)	W (c.c.)	L	M	N	O	P	Q	S
56	9 j6	20	M4	228	221	110	100	M16x1.5	3x3x15	—	—	120	100	80	7	3	8	208
63	11 j6	23	M4	258	241	123	105	M16x1.5	4x4x15	116	96	140	115	95	9	3	9	235
71	14 j6	30	M5	300	275	138	114	M20x1.5	5x5x20	116	96	160	130	110	9	3.5	9	270
80	19 j6	40	M6	335	303	156	126	M20x1.5	6x6x30	124	103	200	165	130	11	3.5	10	295
90S	24 j6	50	M8	365	319	176	133	M20x1.5	8x7x40	134	129	200	165	130	11	3.5	10	315
90L	24 j6	50	M8	390	344	176	133	M20x1.5	8x7x40	134	129	200	165	130	11	3.5	10	340
100	28 j6	60	M10	441	383	192	142	M20x1.5	8x7x40	160	160	250	215	180	14	4	14	381
112	28 j6	60	M10	567	435	216	153	M20x1.5	8x7x40	198	199	250	215	180	14	4	14	425
132 S	38 k6	80	M12	552	477	257	178	M32x1.5	10x8x70	217	266	300	265	230	14	4	20	487
132 M	38 k6	80	M12	605	530	257	178	M32x1.5	10x8x70	217	266	300	265	230	14	4	20	525
160 M	42 k6	110	M16	740	635	310	240	M32x1.5	12x8	247	266	350	300	250	19	5	20	630
160 L	42 k6	110	M16	780	680	310	240	M32x1.5	12x8	247	266	350	300	250	19	5	20	670

12.0 DIMENSIONI

12.0 DIMENSIONS

12.0 ABMESSUNGEN

	B3										B14					
	A	E	E1	F	F1	G	G1	H	I	V	L	M	N	O	P	S
55	—	—	—	—	—	—	—	—	—	—	80	65	50	M5	2.5	145
56	56	36	26	71	90	90	108	6	9	149	80	65	50	M5	2.5	167
63	63	40	28	80	105	100	120	7	10	161	90	75	60	M5	2.5	192
71	71	45	36	90	108	112	136	7	11	178	105	85	70	M6	2.5	220
80	80	50	38	100	125	125	154	9.5	11	204	120	100	80	M6	3	235
90S	90	56	41	100	130	140	174	9.5	13	217	140	115	95	M8	3	250
90L	90	56	41	125	155	140	174	9.5	13	217	140	115	95	M8	3	275
100	100	63	46	140	175	160	192	12	14	238	160	130	110	M8	3.5	310
112	112	70	53	140	180	190	234	12	14	262	160	130	110	M8	3.5	330
132S	132	89	60	140	180	216	256	12	16	310	200	165	130	M10	4	370
132M	132	89	60	178	218	216	256	12	16	310	200	165	130	M10	4	410
160 M	160	108	83	210	260	254	310	15	22	400						
160 L	160	108	72	254	320	254	330	15	22	400						
180 M	180	121	80	241	315	279	355	19	24	450						
180 L	180	121	80	279	353	279	355	19	24	450						
200 L	200	133	91	305	400	318	395	19	27	500						
225 S	225	149	61	286	450	356	435	19	30	550						
225 M	225	149	101	311	450	356	435	19	30	550						
250 M	250	168	108	349	460	406	490	24	33	610						
280 S	280	190	106	368	525	457	550	24	38	670						
280 M	280	190	106	419	576	457	550	24	38	670						
315 S	315	216	112	406	615	508	640	28	48	865						
315 M	315	216	112	457	665	508	640	28	48	865						
315 L	315	216	97	508	745	508	640	28	48	865						
355 M	355	254	174	560	790	610	730	28	52	960						
355 L	355	254	174	630	790	610	730	28	52	960						

	B3 - B5 - B14													B5							
	B		C		D	R		R1		T	U	Z	Key		L	M	N	O	P	Q	S
	2 p	4/6/8 p	2 p	4/6/8 p		2 p	4/6/8 p	2 p	4/6/8 p				2 p	4/6/8 p							
55	9 j6	9 j6	20	20	M4	165	165	—	—	103	76	—	3x3x15	3x3x15	—	—	—	—	—	—	—
56	9 j6	9 j6	20	20	M4	187	187	171	171	110	93	M16x1.5	3x3x15	3x3x15	120	100	80	7	3	8	167
63	11 j6	11 j6	23	23	M4	215	215	193	193	123	98	M16x1.5	4x4x15	4x4x15	140	115	95	9	3	9	192
71	14 j6	14 j6	30	30	M5	250	250	218	218	138	107	M20x1.5	5x5x20	5x5x20	160	130	110	9	3.5	9	218
80	19 j6	19 j6	40	40	M6	275	275	237	237	156	124	M20x1.5	6x6x30	6x6x30	200	165	130	11	3.5	10	235
90S	24 j6	24 j6	50	50	M8	300	300	256	256	176	127	M20x1.5	8x7x40	8x7x40	200	165	130	11	3.5	10	250
90L	24 j6	24 j6	50	50	M8	325	325	281	281	176	127	M20x1.5	8x7x40	8x7x40	200	165	130	11	3.5	10	275
100	28 j6	28 j6	60	60	M10	370	370	310	310	192	138	M20x1.5	8x7x40	8x7x40	250	215	180	14	4	14	308
112	28 j6	28 j6	60	60	M10	390	390	331	331	216	150	M20x1.5	8x7x40	8x7x40	250	215	180	14	4	14	330
132S	38 k6	38 k6	80	80	M12	450	450	376	376	257	178	M25x1.5	10x8x70	10x8x70	300	265	230	14	4	20	370
132M	38 k6	38 k6	80	80	M12	490	490	411	411	257	178	M25x1.5	10x8x70	10x8x70	300	265	230	14	4	20	408
160 M	42 k6	42 k6	110	110	M16	615	615	510	510	310	340	M32x1.5	12x8	12x8	350	300	250	19	5	16	490
160 L	42 k6	42 k6	110	110	M16	659	659	554	554	310	340	M32x1.5	12x8	12x8	350	300	250	19	5	16	535
180 M	48 k6	48 k6	110	110	M16	670	670	570	570	360	270	M32x1.5	14x8	14x9	350	300	250	19	5	18	560
180 L	48 k6	48 k6	110	110	M16	710	710	610	610	360	270	M32x1.5	14x8	14x9	350	300	250	19	5	18	600
200 L	55 k6	55 k6	110	110	M20	775	775	675	675	400	300	M32x1.5	16x10	16x10	400	350	300	19	5	18	665
225 S	—	60 k6	—	140	M20	—	820	690	690	450	325	M50x1.5	—	18x11	450	400	350	19 •	5	20	680
225 M	55 k6	60 k6	110	140	M20	815	845	715	715	450	325	M50x1.5	16x10	18x11	450	400	350	19 •	5	20	705
250 M	60 k6	65 k6	140	140	M20	930	930	800	800	495	360	M50x1.5	18x11	18x11	550	500	450	19 •	5	22	790
280 S	65 k6	75 k6	140	140	M20	1000	1000	880	880	555	390	M63x1.5	18x11	20x12	550	500	450	19 •	5	22	860
280 M	65 k6	75 k6	140	140	M20	1050	1050	930	930	555	390	M63x1.5	18x11	20x12	550	500	450	19 •	5	22	910
315 S	65 k6	80 k6	140	170	M20	1155	1185	1040	1040	630	550	M63x1.5	18x11	22x14	660	600	550	24 •	6	25	1015
315 M	65 k6	80 k6	140	170	M20	1210	1240	1095	1095	630	550	M63x1.5	18x11	22x14	660	600	550	24 •	6	25	1070
315 L	65 k6	80 k6	140	170	M20	1210	1240	1095	1095	630	550	M63x1.5	18x11	22x14	660	600	550	24 •	6	25	1070
355 M	75 k6	95 k6	140	170	M20	1485	1515	1360	1360	715	605	M72x1.5	20x12	25x14	800	740	680	24 •	6	25	1345
355 L	75 k6	95 k6	140	170	M20	1485	1515	1360	1360	715	605	M72x1.5	20x12	25x14	800	740	680	24 •	6	25	1345

• N° 8 fori a 45°

• N° 8 holes 45°

• N° 8 Bohrungen 45°

12.0 DIMENSIONI
DIMENSIONS
ABMESSUNGEN

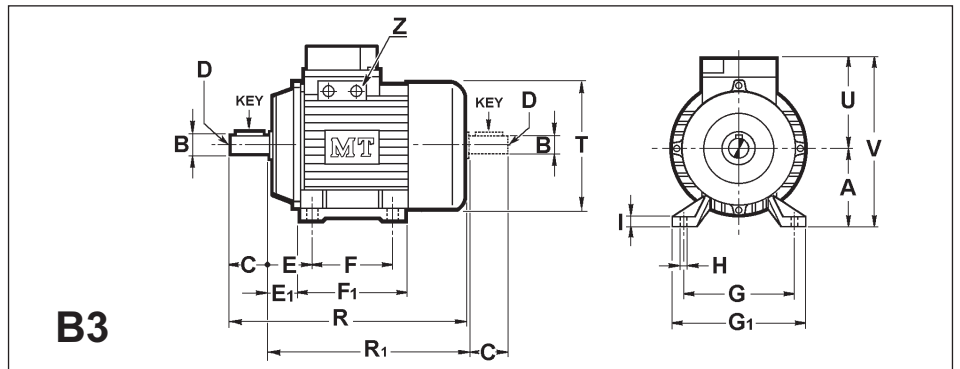
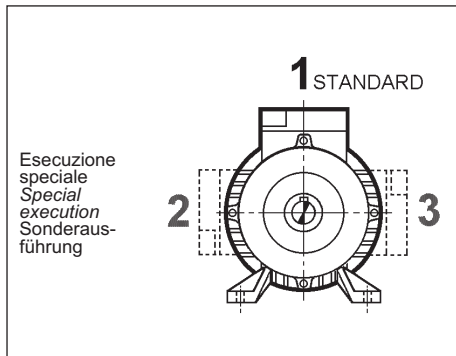
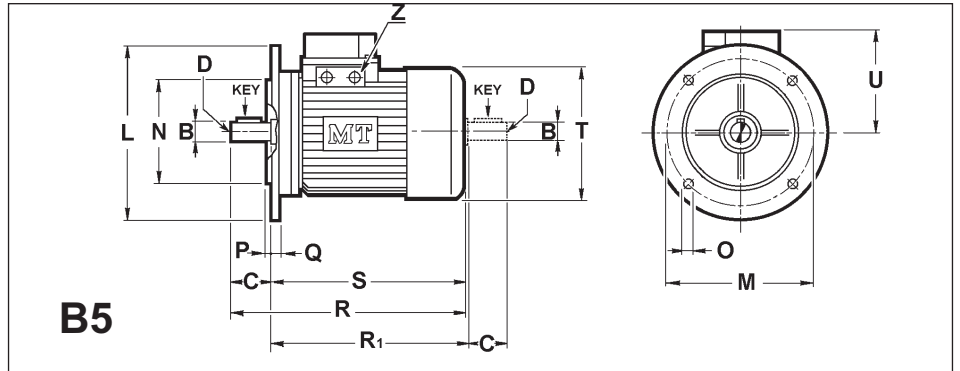
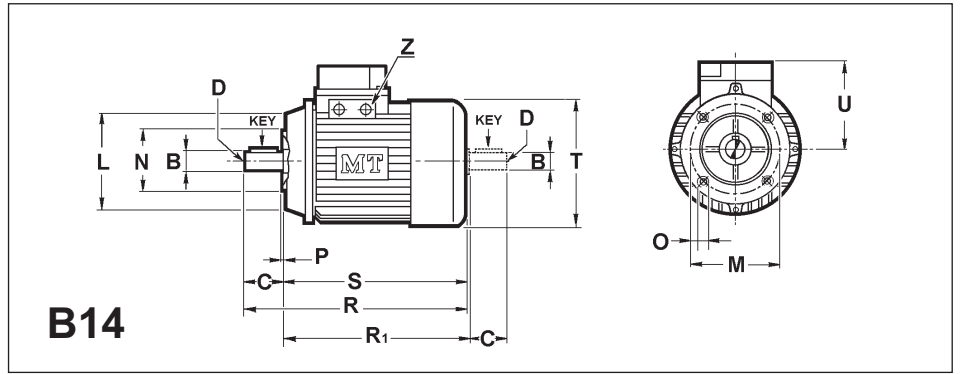
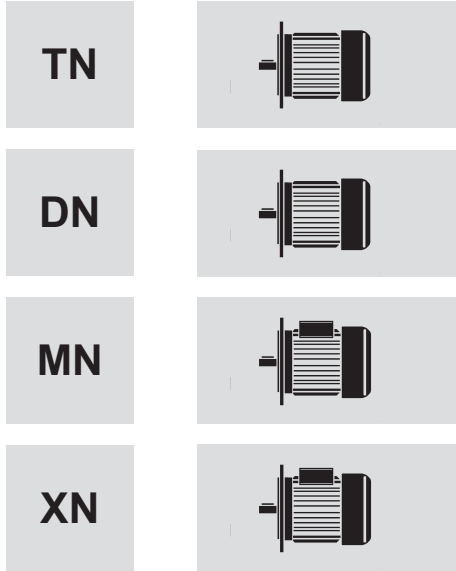

N.B.
 La bisporgenza dell'albero è disponibile
 fino alla GR.132

N.B.
 The double shaft extension is available up
 to size 132.

N.B.
 Die beidseitig vorstehende Welle is bis zur
 Größe 132 verfügbar.

13.0 FRENO A C.C. SERIE FS

13.0 D.C. BRAKE FS SERIES

13.0 Gs - BREMSE SERIE FS

13.1 Caratteristiche tecniche del freno a c.c.

13.1 D.C. brake technical characteristics

13.1 Technische Merkmale der Gs-Bremse

Motore <i>Motor</i>	Mmax Nm	J Kgm ²	T mm	Tn mm	g _{min} mm	TEMPI DI INTERVENTO FRENO <i>BRAKE INTERVENTION TIME</i> <i>BREMSAKTIVIERUNGSZEIT</i>			Kg
						Ta ₁ ms	Ta ₂ ms	Standard Tc ₂ ms	
63	3	3x10 ⁻⁴	0.20	0.50	1	80	8	30	1.1
71	4	5x10 ⁻⁴	0.20	0.50	1	100	10	40	1.3
80	7	10x10 ⁻⁴	0.20	0.60	1	150	15	60	2.1
90	7	11x10 ⁻⁴	0.20	0.60	1	150	15	60	2.1
100	13	30x10 ⁻⁴	0.25	0.70	1	250	25	80	3.6
112	18	34x10 ⁻⁴	0.25	0.70	1	250	25	80	3.9
132	30	50x10 ⁻⁴	0.25	0.70	1	250	25	80	4.2
160	45	50x10 ⁻⁴	0.25	0.45	1	400	40	150	7.3

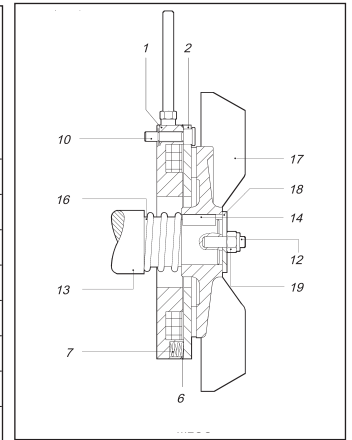

I motori serie TFS sono dotati di freno di stazionamento elettromagnetico con bobina a corrente continua e coppia frenante fissa. L'alimentazione del freno è direttamente collegata alla morsetti del motore tramite un raddrizzatore (in questo modo alimentando il motore il freno contemporaneamente si sblocca).
Il freno può anche essere alimentato separatamente come avviene per i motori a doppia velocità o motori alimentati da inverter.
Questo tipo di freno consente ingombri ridotti e la lunghezza del motore che ne deriva è di poco superiore a quella del motore normale della serie TN.

- Mmax = Coppia frenante
- J = Momento d'inerzia
- T = Valore minimo regolazione traferro
- Tn = Valore max traferro prima della nuova regolazione
- g_{min} = Spessore minimo residuo ferodo
- Ta₁ = Tempo di apertura freno AC
- Ta₂ = Tempo di apertura freno DC
- Tc₂ = Tempo di chiusura standard

The motors of TFS range are equipped with an electromagnetic standing brake, a d.c. coil and fixed braking torque.
The brake feeding is directly connected to the motor terminal board by a rectifier (in this way the brake automatically releases once you feed the motor).
It is possible to adopt brakes with separate feeding, in the same way as it happens with two speed motors or motors working through inverters.
This kind of brake takes up little space, so the resulting motor length is just a little bit superior to the one of TN range motors.

- Mmax = Max braking torque
- J = Moment of inertia
- T = Min. value of air gap setting
- Tn = Max value of air gap before new setting adjustment
- g_{min} = Min thickness of brake lining
- Ta₁ = Brake opening time AC
- Ta₂ = Brake opening time DC
- Tc₂ = Standard brake closing time

Die Motoren der TFS Auswahl sind mit stahenden elektromagnetischen Bremse, Gs Spule und festem Bremsmoment ausgestattet.
Die Bremsspannung ist direkt zur Klammerkasten angeschlossen (auf diese Weise lüft die Motorspannung die Bremse gleichzeitig).
Man kann die Bremse mit separaten Bremsversorgung, wie für doppelte Geschwindigkeit Motoren oder mit Invertersteuerung, erhalten.
Diese Gs Bremse nimmt einen kleinen Platz, so ist die Länge des Motors nur ein Bißchen höhere als der TN Motor.

- Mmax = Max. Bremsmoment
- J = Trägheitsmoment
- T = Min. Luftspaltwert
- Tn = Max. Luftspaltwert vor Neueinstellung
- g_{min} = Mindeststärke Bremsbelag
- Ta₁ = Öffnungszeit der Bremse AC
- Ta₂ = Öffnungszeit der Bremse DC
- Tc₂ = Standard-Schließzeit der Bremse

Il freno a c.c. è fornito di serie con i seguenti valori di alimentazione:

Motore	Alimentazione motore (V)	Alimentazione freno (V)
Trifase standard	230/400 (50/60Hz)	103
Trifase doppia polarità	230(50/60Hz)	103
	400(50/60Hz)	178
Monofase	230(50/60Hz)	103

A richiesta è possibile fornire il freno con alimentazione separata.
Numero max. interventi: 20 al minuto.

N.B. Quando si utilizzano motori autofrenanti a doppia polarità o motori comandati da inverter, si consiglia di adottare l'alimentazione separata del freno.

D.C. brake is supplied with following feeding values:

Motor	Motor feeding (V)	Brake feeding (V)
Threephase standard	230/400 (50/60Hz)	103
Threephase double polarity	230(50/60Hz)	103
	400(50/60Hz)	178
Single phase	230(50/60Hz)	103

Upon request it is possible to supply separate feeded brakes.
Maximum number of starts: 20 for minute.

N.B. When two speed brake motors or motors operated through inverter are used, it is advisable to adopt brakes with separate feeding.

Die Gs-Bremse wird serienmäßig mit folgenden Versorgungsspannungen:

Motor	Motorspannung (V)	Bremsspannung (V)
Drehstrom standard	230/400 (50/60Hz)	103
Drehstrom Polumschaltbar Motoren	230(50/60Hz)	103
	400(50/60Hz)	178
Einphasen	230(50/60Hz)	103

Auf Anfrage ist eine separate Bremsversorgung erhältlich.
Maximale Schaltungsanzahl: 20 pro Minute.

N.B. Bei Bremsmotoren (Polumschaltbar oder mit invertersteuerung) empfiehlt sich eine separate Bremsversorgung.

13.2 **Dimensioni serie FS**
Dimensions FS series
Abmessungen Serie FS

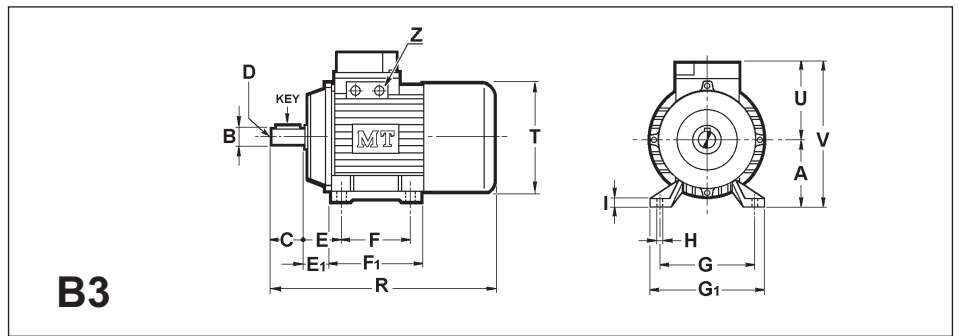
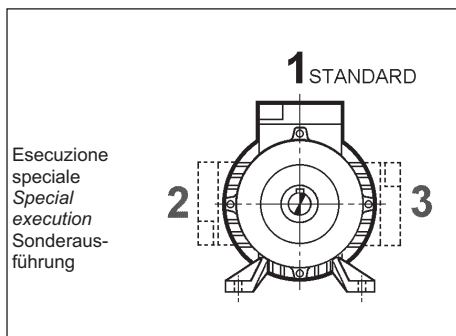
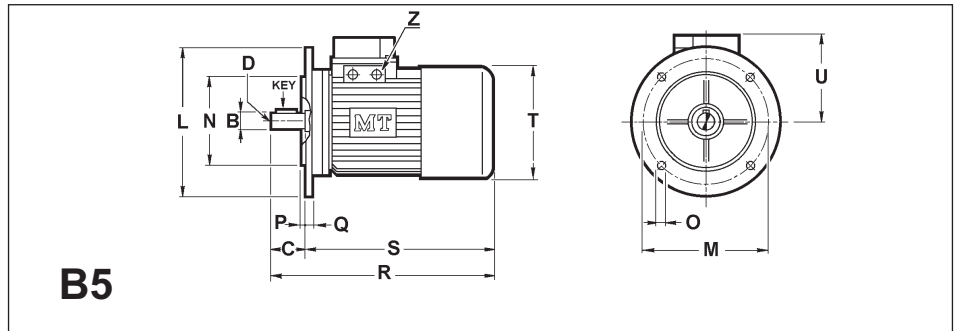
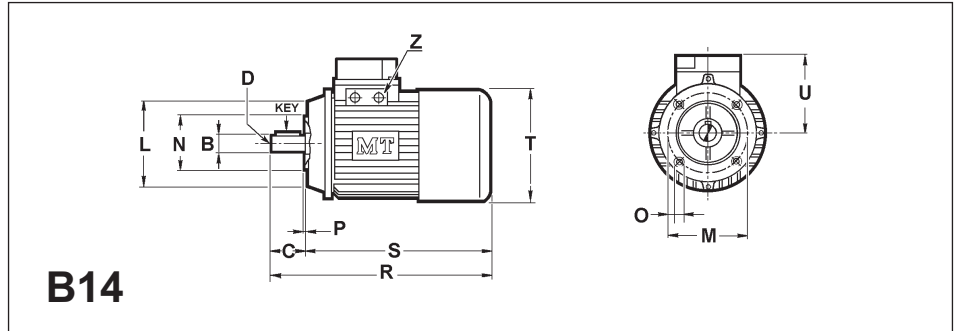
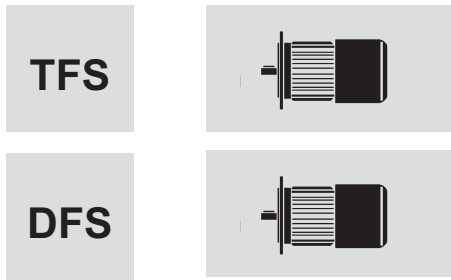

	B3										B14					
	A	E	E1	F	F1	G	G1	H	I	V	L	M	N	O	P	S
56	56	36	26	71	90	90	108	6	9	156	80	65	50	M5	2.5	181
63	63	40	28	80	105	100	120	7	10	168	90	75	60	M5	2.5	202
71	71	45	36	90	108	112	136	7	11	185	105	85	70	M6	2.5	238
80	80	50	38	100	125	125	154	9.5	11	206	120	100	80	M6	3	260
90S	90	56	41	100	130	140	174	9.5	13	223	140	115	95	M8	3	255
90L	90	56	41	125	155	140	174	9.5	13	223	140	115	95	M8	3	278
100	100	63	46	140	175	160	192	12	14	242	160	130	110	M8	3.5	320
112	112	70	53	140	180	190	234	12	14	265	160	130	110	M8	3.5	330
132 S	132	89	60	140	180	216	256	12	16	310	200	165	130	M10	4	420
132 M	132	89	60	178	218	216	256	12	16	310	200	165	130	M10	4	440
160 M	160	108	72	210	260	254	318	15	22	400						
160 L	160	108	72	254	304	254	318	15	22	400						

	B3 - B5 -B14								B5						
	B	C	D	R	T	U	Z	Key	L	M	N	O	P	Q	S
56	9 j6	20	M4	201	110	100	M16x1.5	3x3x15	120	100	80	7	3	8	181
63	11 j6	23	M4	225	123	105	M16x1.5	4x4x15	140	115	95	9	3	9	207
71	14 j6	30	M5	268	138	114	M20x1.5	5x5x20	160	130	110	9	3.5	9	238
80	19 j6	40	M6	300	156	126	M20x1.5	6x6x30	200	165	130	11	3.5	10	260
90S	24 j6	50	M8	305	176	133	M20x1.5	8x7x40	200	165	130	11	3.5	10	265
90L	24 j6	50	M8	329	176	133	M20x1.5	8x7x40	200	165	130	11	3.5	10	286
100	28 j6	60	M10	380	192	142	M20x1.5	8x7x40	250	215	180	14	4	14	324
112	28 j6	60	M10	390	216	153	M20x1.5	8x7x40	250	215	180	14	4	14	330
132 S	38 k6	80	M12	460	257	178	M32x1.5	10x8x70	300	265	230	14	4	20	410
132 M	38 k6	80	M12	520	257	178	M32x1.5	10x8x70	300	265	230	14	4	20	440
160 M	42 k6	110	M16	610	310	240	M32x1.5	12x8	350	300	250	19	5	20	500
160 L	42 k6	110	M16	650	310	240	M32x1.5	12x8	350	300	250	19	5	20	540

14.0 FRENO A C.A. SERIE FP

14.0 A.C. BRAKE FP SERIES

14.0 Ws - BREMSE SERIE FP

14.1 Caratteristiche tecniche del freno a c.a.

14.1 A.C. brake technical characteristics

14.1 Technische Merkmale der Ws-Bremse

Motore Motor Motor	Mmin Nm	Mmax Nm	P VA	I _N (230V) A	I _N (400V) A	J Kgm ²	T mm	Tn mm	g _{min} mm	TEMPI DI INTERVENTO FRENO BRAKE INTERVENTION TIME BREMSAKTIVIERUNGSZEIT		Kg
										Ta ms	Tc ms	
63	2	8	75	0.19	0.11	2x10 ⁻⁴	0.30	0.70	1	20	4	2.3
71	4	18	110	0.28	0.16	3x10 ⁻⁴	0.30	0.70	1	25	4	2.8
80	7	35	185	0.47	0.27	7x10 ⁻⁴	0.30	0.70	1	25	6	4.0
90	14	50	225	0.55	0.32	12x10 ⁻⁴	0.30	0.70	1	35	8	5.4
100	26	75	270	0.67	0.39	16x10 ⁻⁴	0.30	0.70	1	35	8	7.0
112	35	100	330	0.83	0.48	30x10 ⁻⁴	0.40	0.80	1	40	10	10.3
132	53	150	530	1.31	0.76	50x10 ⁻⁴	0.40	0.80	1	60	15	19.0
160	70	200	760	1.91	1.10	60x10 ⁻⁴	0.50	1.00	1	60	15	29.0
180M	100	300	825	2.1	1.2	150x10 ⁻⁴	0.50	1.30	1	100	25	42
180L	175	500	825	2.1	1.2	280x10 ⁻⁴	0.65	1.30	1	100	25	48
200	270	750	1100	2.8	1.6	280x10 ⁻⁴	0.65	1.30	1	170	35	52

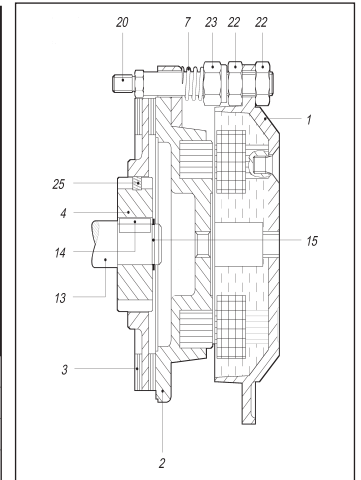

E' un motore con freno elettromagnetico a molle, funzionante a c.a. con disco a doppia superficie frenante. Concepito per la massima precisione di sblocco e frenatura, massima frequenza di frenatura ed elevata frequenza di avviamenti. Freno con tensione di alimentazione trifase 230/400V-50Hz con collegamento del freno simile ad un motore asincrono trifase. Nel coprimorsettiera vi è una morsettiera con 6 morsetti M4 per permettere un'alimentazione separata del freno (normalmente il motore viene fornito con alimentazione del freno direttamente alla morsettiera del motore). Tutti i motori vengono forniti con vite per lo sblocco manuale del freno, che consente di poter ruotare l'albero motore manualmente con una chiave esagonale maschio di 5 mm per le grandezze 63-100 e 6 mm per le grandezze 112-200.

Tutti i motori autofrenanti sono forniti di serie con la coppia del freno tarata ad un valore pari al 70% circa della coppia massima.

This motor is equipped with an electromagnetic springs brake, it works with a.c. and the disk brake has double braking surface. This motor has been projected to achieve the highest release and braking precision, the maximum braking frequency and high starting frequency.

The brake works with a threephase feeding current 230/400V – 50 Hz, the brake connection is similar to the one of a threephase asynchronous motor. In the terminal box cover there is a terminal board with 6 terminals M4, able to allow a separate feeding of the brake (usually the motor is supplied with the brake fed directly to the motor terminal board). All the motors are provided with the screw for the brake hand release. Therefore it is possible to rotate manually the output shaft with a full shaft hexagonal key of 5 mm, for the 63 – 100 sizes, and of 6 mm, for the 112 – 200 sizes.

All brake motors in the standard version are supplied with a brake torque set to a value equal to approx. 70% of the maximum torque.

Das ist ein Motor mit elektromagnetischen Federbremse. Diese Ws Bremse funktioniert mit einer doppelten- Bremsfläche. Das haben wir ausgedacht, um die höchste Genauigkeit der Entsperrung und der Bremsung, die höchste Häufigkeit der Bremsung und eine hohe Häufigkeit der Anläufe zu erteilen. Bremsversorgung mit Drehstrom 230/400V – 50 HZ, die Verbindung der Bremse ist ähnlich den Drehstrom Asynchronmotoren. In der Bedeckung der Klammerkasten gibt es eine Klammerkasten mit 6 Klemmen M4, um die separate Bremsversorgung zu erlauben (normalerweise wird der Motor mit dem Anschluß der Spannung direkt zur Klammerkasten geliefert). Alle Motoren werden mit eine schraube für die luftung der Bremse. Diese schraube erlaubt die Rotation der Motorwelle von Hand. Man braucht einen sechskantigen Einsteckschlüssel von 5 mm für 63 – 100 Größen und 6 mm für 112 – 200 Größen.

Alle Bremsmotoren sind serienmäßig mit eiem Bremsmoment ausgestattet, das auf einen Wert

- Mmin = Coppia frenante min
- Mmax = Coppia frenante max
- I_N = Corrente assorbita a 230 e 400V
- J = Momento d'inerzia bussola
- P = Potenza
- T = Valore minimo regolazione traferro
- Tn = Valore max traferro prima della nuova regolazione
- g_{min} = Spessore minimo residuo ferodo
- Ta = Tempo di apertura freno
- Tc = Tempo di chiusura freno

- Mmin = Min braking torque
- Mmax = Max braking torque
- I_N = Absorbed current at 230 and 400V
- J = Moment of inertia of magnet
- P = Power
- T = Min. value of air gap setting
- Tn = Max value of air gap before new setting adjustment
- g_{min} = Min thickness of brake lining
- Ta = Brake opening time
- Tc = Brake closing time

- Mmin = Min. Bremsmoment
- Mmax = Max. Bremsmoment
- I_N = Nennstrom der Bremse bei 230 und 400V
- J = Trägheitsmoment der Buchse
- P = Leistung
- T = Min. Luftspaltwert
- Tn = Max. Luftspaltwert vor Neueinstellung
- g_{min} = Mindeststärke Bremsbelag
- Ta = Öffnungszeit der Bremse
- Tc = Schließzeit der Bremse

Il freno a c.a. è fornito di serie con i seguenti valori di alimentazione:

Motore	Alimentazione motore (V)	Alimentazione freno (V)
Trifase standard	230/400	230/400
Trifase doppia polarità	230	230/400
	400	

Questo tipo di motore può avere il freno a c.c. Con raddrizzatore per ottenere frenature più dolci.

A.C. brake is supplied with following feeding values:

Motor	Motor feeding (V)	Brake feeding (V)
Threephase standard	230/400	230/400
Threephase double polarity	230	230/400
	400	

This range of motor can be provided of a d.c. Brake with rectifier in order to allow milder braking.

Die Ws-Bremse wird serienmäßig mit folgenden Versorgungsspannungen:

Motor	Motorspannung (V)	Bremsspannung (V)
Drehstrom standard	230/400	230/400
Drehstrom Polumschalt.Mot.	230	230/400
	400	

Um leichtere Bremsungen zu erlauben, kann dieser Motor eine Gs-Bremse mit Gleichrichter haben.

14.2 Dimensioni serie FP
 Dimensions FP series
 Abmessungen Serie FP

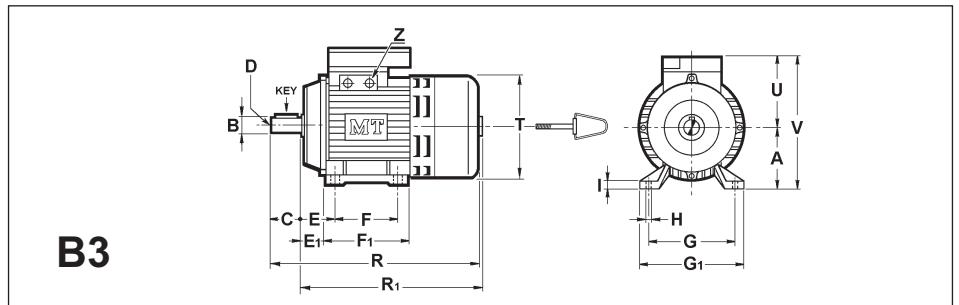
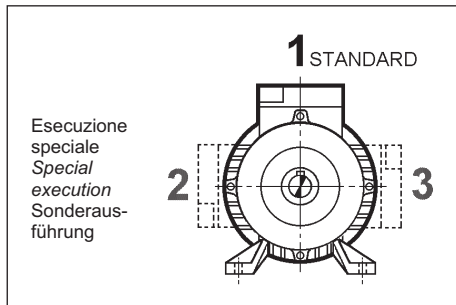
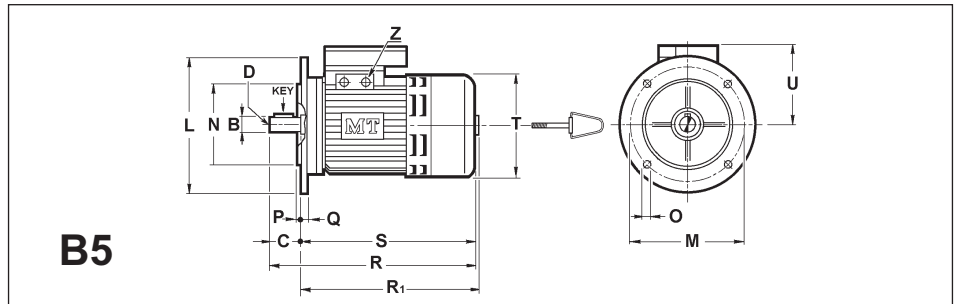
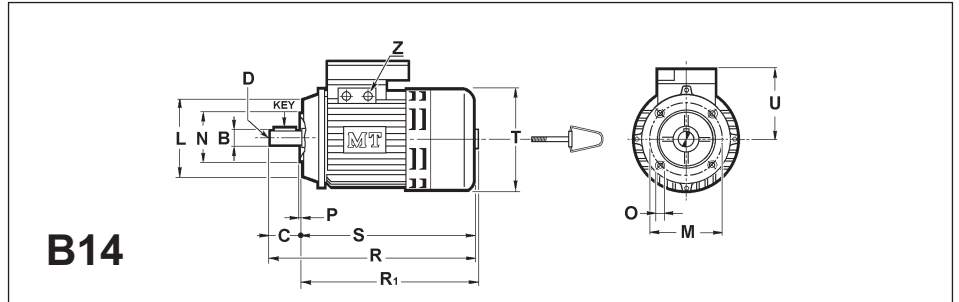
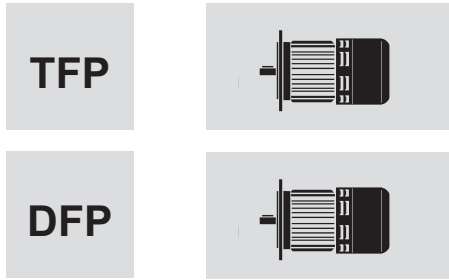

	B3										B14					
	A	E	E1	F	F1	G	G1	H	I	V	L	M	N	O	P	S
63	63	40	28	80	105	100	120	7	10	168	90	75	60	M5	2.5	272
71	71	45	36	90	108	112	136	7	11	185	105	85	70	M6	2.5	303
80	80	50	38	100	125	125	154	9.5	11	206	120	100	80	M6	3	332
90 S	90	56	41	100	130	140	174	9.5	13	223	140	115	95	M8	3	355
90 L	90	56	41	125	155	140	174	9.5	13	223	140	115	95	M8	3	380
100	100	63	46	140	175	160	192	12	14	242	160	130	110	M8	3.5	415
112	112	70	53	140	180	190	234	12	14	265	160	130	110	M8	3.5	435
132 S	132	89	60	140	180	216	256	12	16	310	200	165	130	M10	4	544
132 M	132	89	60	178	218	216	256	12	16	310	200	165	130	M10	4	582
160 M	160	108	82	210	260	254	310	15	22	400	250	215	180	M10	4	665
160 L	160	108	82	254	320	254	330	15	22	400	250	215	180	M10	4	700
180	180	121	96	279	329	279	359	13	25	436	—	—	—	—	—	—
200	200	133	108	305	355	318	398	20.5	25	456	—	—	—	—	—	—

	B3 - B5 - B14									B5						
	B	C	D	R	R1	T	U	Z	Key	L	M	N	O	P	Q	S
63	11	23	M4	305	295	124	105	M16x1.5	4x4x15	140	115	95	9	3	9	272
71	14	30	M5	333	313	140	114	M20x1.5	5x5x20	160	130	110	9	3.5	9	303
80	19	40	M6	372	342	158	126	M20x1.5	6x6x30	200	165	130	11	3.5	10	332
90 S	24	50	M8	405	365	178	133	M20x1.5	8x7x40	200	165	130	11	3.5	10	355
90 L	24	50	M8	430	390	178	133	M20x1.5	8x7x40	200	165	130	11	3.5	10	380
100	28	60	M10	475	425	198	142	M20x1.5	8x7x40	250	215	180	14	4	14	415
112	28	60	M10	495	445	222	153	M20x1.5	8x7x40	250	215	180	14	4	14	435
132 S	38	80	M12	624	554	255	178	M32x1.5	10x8x70	300	265	230	14	4	20	544
132 M	38	80	M12	662	592	255	178	M32x1.5	10x8x70	300	265	230	14	4	20	582
160 M	42	110	M16	775	671	317	340	M32x1.5	12x8x90	350	300	250	19	5	16	665
160 L	42	110	M16	819	715	317	340	M32x1.5	12x8x90	350	300	250	19	5	16	709
180	48	110	M16	940	935	360	256	M32x1.5	14x8	350	300	250	19	5	20	830
200	55	110	M20	955	850	360	256	M32x1.5	16x10	400	350	300	19	5	20	845

14.3 VERIFICHE E REGOLAZIONI

Tutti I motori vengono collaudati e la taratura dei freni viene effettuata ad un valore pari al 70% circa della coppia massima in base a una tensione di alimentazione di 400 Volt.

Nel caso in cui si avvertano vibrazioni nel freno, è opportuno effettuare i seguenti controlli e relativi interventi per riportare il sistema alle normali condizioni operative:

- 1) Verificare la tensione di alimentazione.
Se essa è inferiore a 400 Volt, provvedere a riportarla al valore nominale oppure intervenire riducendo la pressione delle molle agendo come indicato al punto 3.
- 2) Verifica del traferro.
Con uno spessore misurare il traferro T (distanza fra l'elettromagnete e l'ancora mobile), controllando che il valore rilevato rientri nel campo indicato in tabella. Se questa condizione non fosse verificata, sarà necessario effettuare la regolazione allentando i dadi 22 fino a che il traferro non avrà raggiunto il valore prestabilito. Ad operazione conclusa, stringere nuovamente i dadi 22. Questo controllo e l'eventuale intervento dovranno essere effettuati periodicamente ad intervalli stabiliti in base all'utilizzo del freno.
- 3) Regolazione della coppia frenante.
La coppia frenante è proporzionale alla compressione delle molle ed è possibile variarla agendo sul dado n° 23 (n°3 per motori grand. 63-112 e n° 6 per grand. 132-200) in successione e in modo uniforme; a tale proposito si consiglia di effettuare una rotazione di $\frac{1}{2}$ giro a ciascun dado di regolazione e riprovare il funzionamento del freno

14.3 CHECKS AND ADJUSTMENTS

All motors are tested and brakes are set to a value equal to 70% of the maximum torque based on a 400 V supply voltage.

Should vibrations be noticed in the brake it is advisable to check as indicated below and carry out the relative operations to bring the system back to normal working conditions:

- 1) *Check the supply tension.*
Should it be lower than 400 Volts, bring it back to the nominal value or reduce the pressure of the springs by regulating as indicated at point 3.
- 2) *Checking of the magnetic gap.*
Using a feeler gauge, measure the T magnetic gap (distance between the electromagnet and the mobile keeper) checking that the measured value falls within the range indicated in the chart. Should this condition not occur, an adjustment must be made by unloosening screw nuts 22 until the magnetic gap has reached the preset value. When this operation is finished, tighten screw nuts 22. This check and the relative adjustment, if performed, must be carried out periodically at intervals set according to how much the brake is used.
- 3) *Adjusting of the braking torque.*
The braking torque is proportional to the compression of springs and it is possible to change it by regulating the nut n. 23 (n° 3 for motors size 63-112 and n° 6 for motors size 132-200) in sequence and in a uniform manner; on this matter, it is advisable to rotate each nut by $\frac{1}{2}$ turn and retry the brake functioning.

14.3 KONTROLLEN UND EINSTELLUNGEN

Alle Motoren werden zugelassen und die Eichung der Bremsen wird bei einem Wert von 70% des Höchstdrehmomentes bei einer Versorgungsspannung von 400 Volt ausgeführt.

Sollten in der Bremse Vibrationen festgestellt werden, so sollten die folgenden Kontrollen und die entsprechenden Instandsetzungsarbeiten durchgeführt werden, um das System wieder auf die normalen Betriebsbedingungen zurückzuführen:

- 1) Die Versorgungsspannung überprüfen.
Sollte diese unter 400 Volt liegen, so sollte sie auf den Nominalwert zurückgeführt werden. Andernfalls kann die Spannung der Federn reduziert werden, indem wie unter Punkt 3 beschrieben vorgegangen wird.
- 2) Den Luftspalt überprüfen.
Mit einem Dickenmesser den Luftspalt T (Distanz zwischen Elektromagnet und Ankerscheibe) abmessen und dabei überprüfen, ob der festgestellte Wert innerhalb des in der Tabelle angegebenen Bereiches liegt. Sollte dies nicht der Fall sein, muß die Einstellung neu ausgeführt werden. Dazu die Schraubenmuttern 22 lösen, bis der Luftspalt den vorgeschriebenen Wert erreicht. Ist dies geschehen, so müssen die Schraubenmuttern 22 wieder angezogen werden. Diese Kontrolle und die eventuell erforderliche Neueinstellung sollten regelmäßig in Intervallen, die den Einsatzzeiten der Bremse entsprechen, ausgeführt werden.
- 3) Einstellung des Bremsmoments.
Das Bremsmoment ist proportional zur Druckspannung der Federn und es kann durch aufeinanderfolgendes und gleichmäßiges Einwirken auf die Schraubenmuttern n. 23 (n° 3 für die Größen 63-112 und n° 6 für die Größen 132-200) variiert werden. Diesbezüglich ist es empfehlenswert, jeweils eine halbe Drehung auf jeder Einstellungsschraube auszuführen und dann den Betrieb der Bremse erneut zu überprüfen.

15.0 PARTI DI RICAMBIO

La seguente lista è riferita ai motori elettrici tipo T., D., M...
Per l'ordinazione è necessario specificare:

- 1 tipo del motore
- 1 denominazione della parte di ricambio

15.0 SPARE PARTS

The following list is referred to electrical motors type T., D., M...
When placing an order it is necessary to specify:

- 1 type of motor
- 1 nomenclature of spare part

15.0 ERSATZTEILE

Die nachstehende Ersatzteilliste bezieht sich auf Elektromotoren vom Typ T., D., M... Bei der Bestellung ist folgendes anzugeben:

- 1 Motortyp
- 1 Bezeichnung des Ersatzteils

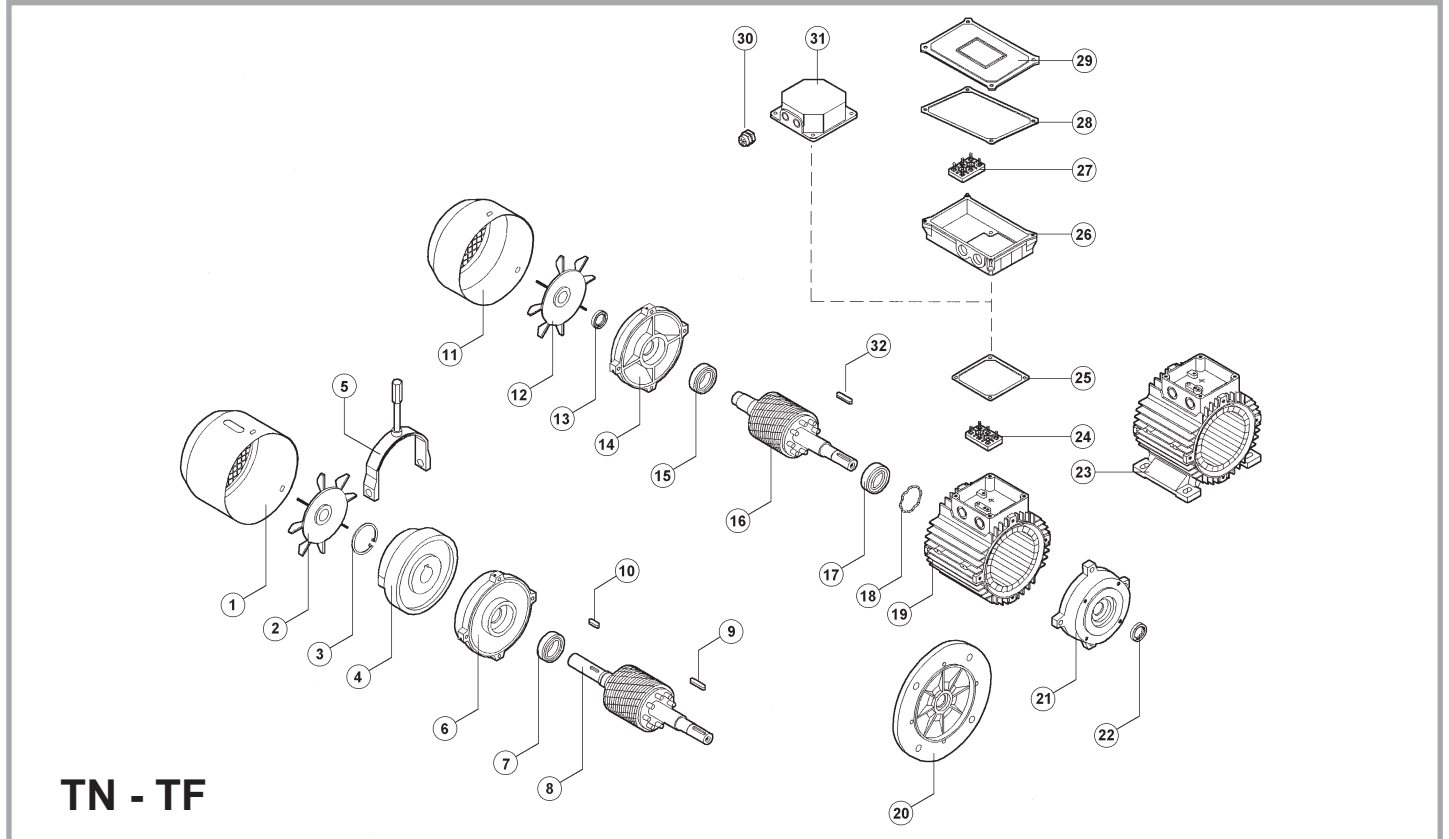

TN - TF

1	Copriventola	Fan cover	Lüfterhaube
2	Ventola	Fan	Lüfter
3	Seeger	Circlip	Seeger
4	Freno	Brake	Bremse
5	Leva di sblocco	Hand release	Handlüftung
6	Scudo posteriore	Non drive end shield	Hinteres Lagerschild
7	Cuscinetto	Bearing	Lager
8	Rotore	Rotor	Rotor
9	Linguetta	Key	Keil
10	Linguetta	Key	Keil
11	Copriventola	Fan cover	Lüfterhaube
12	Ventola	Fan	Lüfter
13	Anello di tenuta	Oilseal	Dichtring
14	Scudo posteriore	Non drive end shield	Hinteres Lagerschild
15	Cuscinetto	Bearing	Lager
16	Rotore	Rotor	Rotor
17	Cuscinetto	Bearing	Lager
18	Molla di precarico	Pre load spring	Vorspannfedern
19	Cassa B5-B14	B5/B14 housing	Gehäuse B5-B14
20	Flangia B5	B5 Flange	Flansch B5
21	Scudo anteriore (B14)	Drive end shield (B14)	Vorderes Lagerschild (B14)
22	Anello di tenuta	Oilseal	Dichtring
23	Cassa con piedi	Foot casing	Gehäuse mit Fuß
24	Morsettiere	Terminal board	Klembrett
25	Guarnizione	Gasket	Dichtung
26	Scatola morsettiere	Terminal box	Klemmenkasten
27	Morsettiere	Terminal board	Klembrett
28	Guarnizione	Gasket	Dichtung
29	Coperchio morsettiere	Terminal box cover	Klemmenkastendeckel
30	Pressacavo	Cable gland	Kabelverschraubung
31	Scatola morsettiere	Terminal box	Klemmenkasten
32	Linguetta	Key	Keil

	Cuscinetti Bearings Kugellager 15 — 17	Cuscinetti Bearings Kugellager 7
55	6201-2Z	—
56	6201-2Z	6201-2RS
63	6202-2Z	6202-2RS
71	6203-2Z	6003-2RS
80	6204-2Z	6204-2RS
90	6205-2Z	6205-2RS
100	6206-2Z	6206-2RS
112	6306-2Z	6306-2RS
132	6308-2Z	6308-2RS
160	6309-2Z	6309-2RS
180	6310-2Z	—
200	6312-2Z	—

16.0 PARTI DI RICAMBIO

La seguente lista è riferita ai motori elettrici tipo T..., D..
Per l'ordinazione è necessario specificare:

- 1 tipo del motore
- 1 denominazione della parte di ricambio

16.0 SPARE PARTS

The following list is referred to electrical motors type T..., D..
When placing an order it is necessary to specify:

- 1 type of motor
- 1 nomenclature of spare part

16.0 ERSATZTEILE

Die nachstehende Ersatzteilliste bezieht sich auf Elektromotoren vom Typ T..., D..
Bei der Bestellung ist folgendes anzugeben:

- 1 Motortyp
- 1 Bezeichnung des Ersatzteils

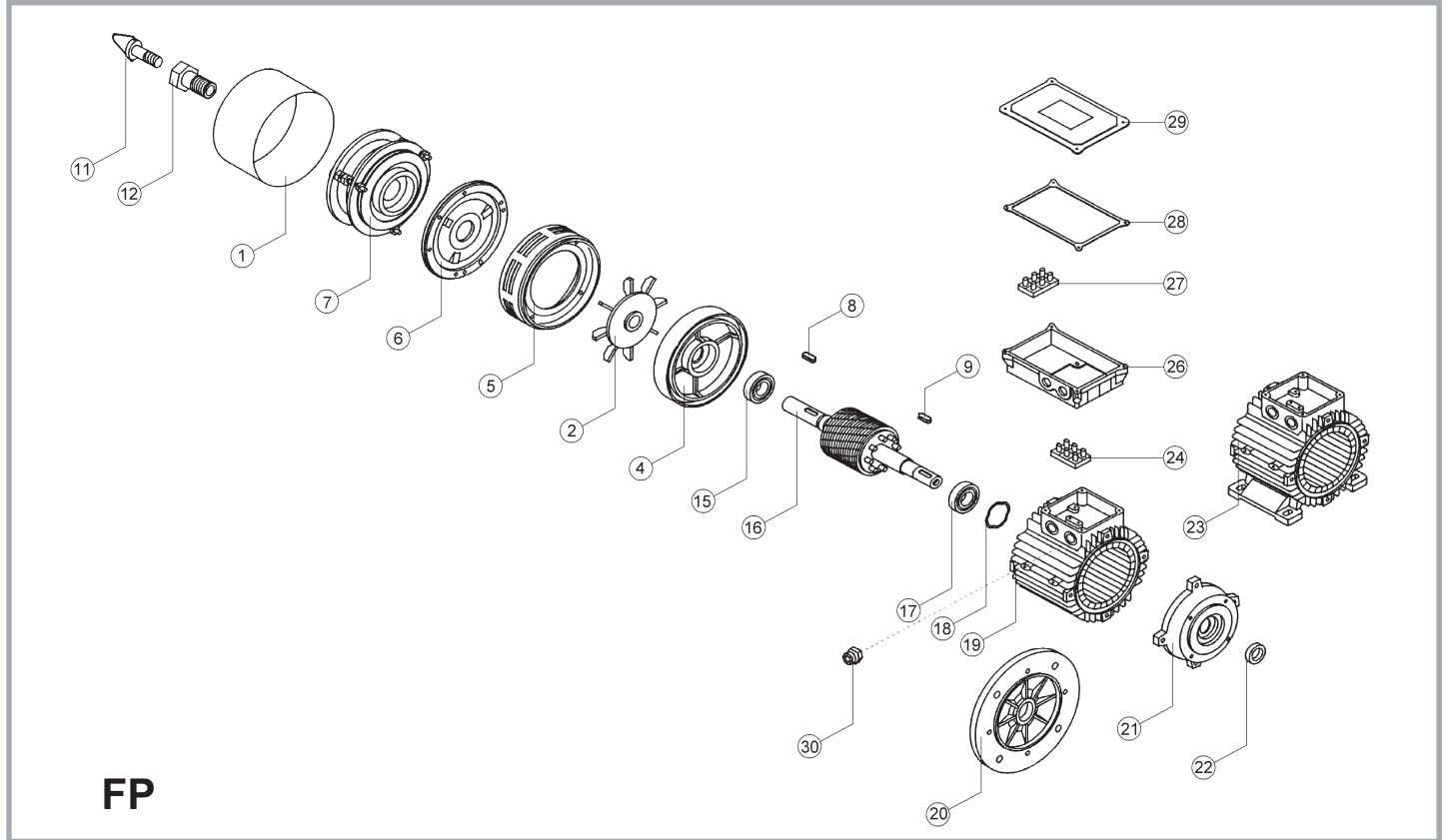

FP

1	Coprifreno	Brake cover	Brense Bedeckung
2	Ventola	Fan	Lüfter
4	Scudo posteriore	Non drive end shield	Hinteres Lagerschild
5	Convogliatore	Conveyor	Fürderwerk
6	Flangia frenante	Braking torque	Bremsmoment
7	Gruppo Freno Serie P	Brake group Range P	Bremse Gruppe Auswahl P
8	Linguetta	Key	Keil
9	Linguetta	Key	Keil
11	Vite sblocco freno	Screw for brake release	Schraube für Bremse luftung
12	Dado fissaggio Coprifreno	Nut fixing the brake cover	Fixierschraubenmutter für Bremse Bereckung
15	Cuscinetto	Bearing	Lager
16	Rotore	Rotor	Rotor
17	Cuscinetto	Bearing	Lager
18	Molla di precarico	Pre load spring	Vorspannfedern
19	Cassa B5-B14	B5-B14 housing	Gehäuse B5-B14
20	Flangia B5	B5 Flange	Flansch B5
21	Scudo anteriore (B14)	Drive end shield (B14)	Vorderes Lagerschild (B14)
22	Anello di tenuta	Oilseal	Dichtring
23	Cassa con piedi	Foot casing	Gehäuse mit Fuß
24	Morsettieria	Terminal board	Klemmbrett
26	Scatola morsettieria	Terminal box	Klemmenkasten
27	Morsettieria	Terminal board	Klemmbrett
28	Guarnizione	Basket	Dichtung
29	Coperchio morsettieria	Terminal box cover	Klemmenkastendeckel
30	Pressacavo	Cable gland	Kabelverschraubung

	Cuscinetti Bearings Kugellager 17	Cuscinetti Bearings Kugellager 15
63	6202-2Z	6202-2RS
71	6203-2Z	6003-2RS
80	6204-2Z	6204-2RS
90	6205-2Z	6205-2RS
100	6206-2Z	6206-2RS
112	6306-2Z	6306-2RS
132	6308-2Z	6308-2RS
160	6309-2Z	6309-2RS
180	6310-2Z	6312-2RS
200	6312-2Z	6312-2RS

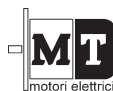

DICHIARAZIONE DI CONFORMITA' DEL COSTRUTTORE
MANUFACTURER'S DECLARATION OF CONFORMITY

IL PRODOTTO

Motori elettrici asincroni trifase e monofase

(TIPO - SERIE)

TN - DN - MN - XN - TF - DF - MF - XF - TFS - DFS - TFP - DFP

GRANDEZZA:

55 / 200L

THE PRODUCT

Asynchronous three-phase and single-phase motors

(TYPE - VERSION)

TN - DN - MN - TF - DF - MF - TFS - DFS - TFP - DFP

SIZE:

55 / 200L

SONO STATI PROGETTATI E COSTRUITI IN ACCORDO
CON LE NORME:

Nazionali: CEI EN 60034-1 10/2000

CORRISPONDENTE ALLE IEC: IEC 60034-1 11/1996,
IEC 60034-1/A1 06/1997, IEC 60034-1/A2 05/1999.

INCLUDE LA DIRETTIVA BASSA TENSIONE

CEE 73/23 (1973), MODIFICATA CON CEE 93/68 (1993)

E LA DIRETTIVA EMC CEE 89/336

HAVE BEEN DESIGNED AND MANUFACTURED IN
ACCORDANCE WITH THE FOLLOWING

National: CEI EN 60034-1 10/2000

CORRESPONDING TO IEC: IEC 60034-1 11/1996,
IEC 60034-1A1 06/1997, IEC 60034-1A2 05/1999.

IT INCLUDES THE EEC LOW VOLTAGE DIRECTIVE

73/23 (1973), MODIFIED BY EEC 93/68 (1993) AND THE

EEC EMC DIRECTIVE 89/336







**IN ARMONIA ALLE DISPOSIZIONI UL 1004 EDIZIONE V
DEL 03/06/1994**

**FOLLOWING THE PROVISIONS OF UL 1004
ISSUE V OF 03/06/1994**

**CONFORMEMENTE ALLA DIRETTIVA ATEX DIR. 94/9/CE E
ALLE NORME RELATIVE ALL'UTILIZZO IN ATMOSFERA
ESPLOSIVA EN 50014 ED EN 50021**

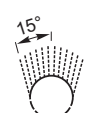
**IN ACCORDANCE WITH THE DIRECTIVE ATEX DIR.
94/9/CE AND THE RULES EN 50014 AND EN 50021
RELATED TO THE UTILIZATION IN EXPLOSIVE AMBIENT**

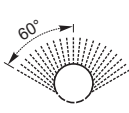
GENERAL MANAGER

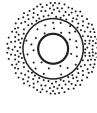
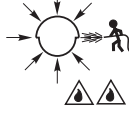
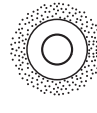
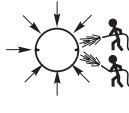
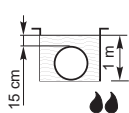
Protezione contro i corpi solidi Protection against foreign bodies Ziffer: Schutzart gegen feste Fremdkörper			Protezione contro i liquidi Protection against water Ziffer: Schutzart gegen das Eindringen von Wasser		
IP	Prove Proof Prüfungen	Definizione Description Definition	IP	Prove Proof Prüfungen	Definizione Description Definition
0		Nessuna protezione <i>No protection</i> Kein Schutz	0		Nessuna protezione <i>No protection</i> Kein Schutz
1	 Ø 52.5 mm	Protetto contro i corpi solidi superiori a 50 mm (esempio: contatti involontari della mano) <i>Protection against solid foreign bodies of thickness greater than 50 mm (ex. involuntary contacts of the hand)</i> Geschützt gegen feste Fremdkörper größer als 50 mm (z.B. zufälliges Berühren mit der Hand)	1		Protetto contro la caduta verticale di gocce d'acqua (condensa) <i>Protection against vertical drops of water (condensation)</i> Geschützt gegen Wassertropfen, die senkrecht fallen (Kondenswasser)
2	 Ø 12.5 mm	Protetto contro i corpi solidi superiori a 12 mm (esempio: dita della mano) <i>Protection against solid foreign bodies of thickness greater than 12 mm (ex. fingers of the hand)</i> Geschützt gegen feste Fremdkörper größer als 12 mm (z.B. Fingern)	2	 15°	Protetto contro la caduta verticale di gocce d'acqua fino a 15° dalla verticale <i>Protection against vertical drops of water until 15° from the vertical</i> Geschützt gegen Wassertropfen, die in einem beliebigen Winkel bis 15° Senkrechten fallen
3	 Ø 2.5 mm	Protetto contro i corpi solidi superiori a 2.5 mm (esempio: fili, utensili) <i>Protection against solid foreign bodies of thickness greater than 2,5 mm (ex. wires, tools)</i> Geschützt gegen feste Fremdkörper größer als 2,5 mm (Werkzeugen, Drähte)	3	 60°	Protetto contro le cadute d'acqua a pioggia fino a 60° dalla verticale <i>Protection against sprinkle water until 60° from the vertical</i> Geschützt gegen Wasser, das in einem beliebigen Winkel bis 60° zur Senkrechten fällt
4	 Ø 1 mm	Protetto contro i corpi solidi superiori a 1 mm (esempio: fili sottili, utensili fini) <i>Protection against solid foreign bodies of thickness greater than 1 mm (ex. thin wire, fine tools)</i> Geschützt gegen feste Fremdkörper größer als 1 mm (dünne Werkzeuge, dünne Drähte)	4		Protetto contro i getti d'acqua provenienti da tutte le direzioni <i>Protection against jets of water from any direction</i> Geschützt gegen Wasser, das aus allen Richtungen spritzt
5		Protetto contro le polveri (nessun deposito nocivo) <i>Protection against ingress of dust (no harmful deposit)</i> Geschützt gegen Staub (keine schädliche Ablagerung)	5		Protetto contro i getti d'acqua con lancia da tutte le direzioni <i>Protection against water projected by a nozzle from any direction</i> Geschützt gegen Wasserstrahl aus einer Düse, der aus allen Richtungen gerichtet wird
6		Totalmente protetto contro le polveri <i>Complete protection against ingress of dust</i> Vollständig geschützt gegen Eindringen von Staub	6		Protetto contro le proiezioni d'acqua simili a onde marine <i>Protection against water projections similar to sea waves</i> Geschützt gegen starkes Strahlwasser, wie schwere Seen
			7	 15 cm	Protetto contro gli effetti dell'immersione <i>Protection against the effects of immersion</i> Geschützt gegen die Wirkungen beim Eintauchen