

### Getriebelege und unten liegende Gehäusefläche

Mounting positions and surface below  
 Posizioni di montaggio e superficie sotto  
 Positions de montage e surface en bas  
 Posición de montaje y superficie debajo  
 Posição de montagem e superfície 1 de baixo

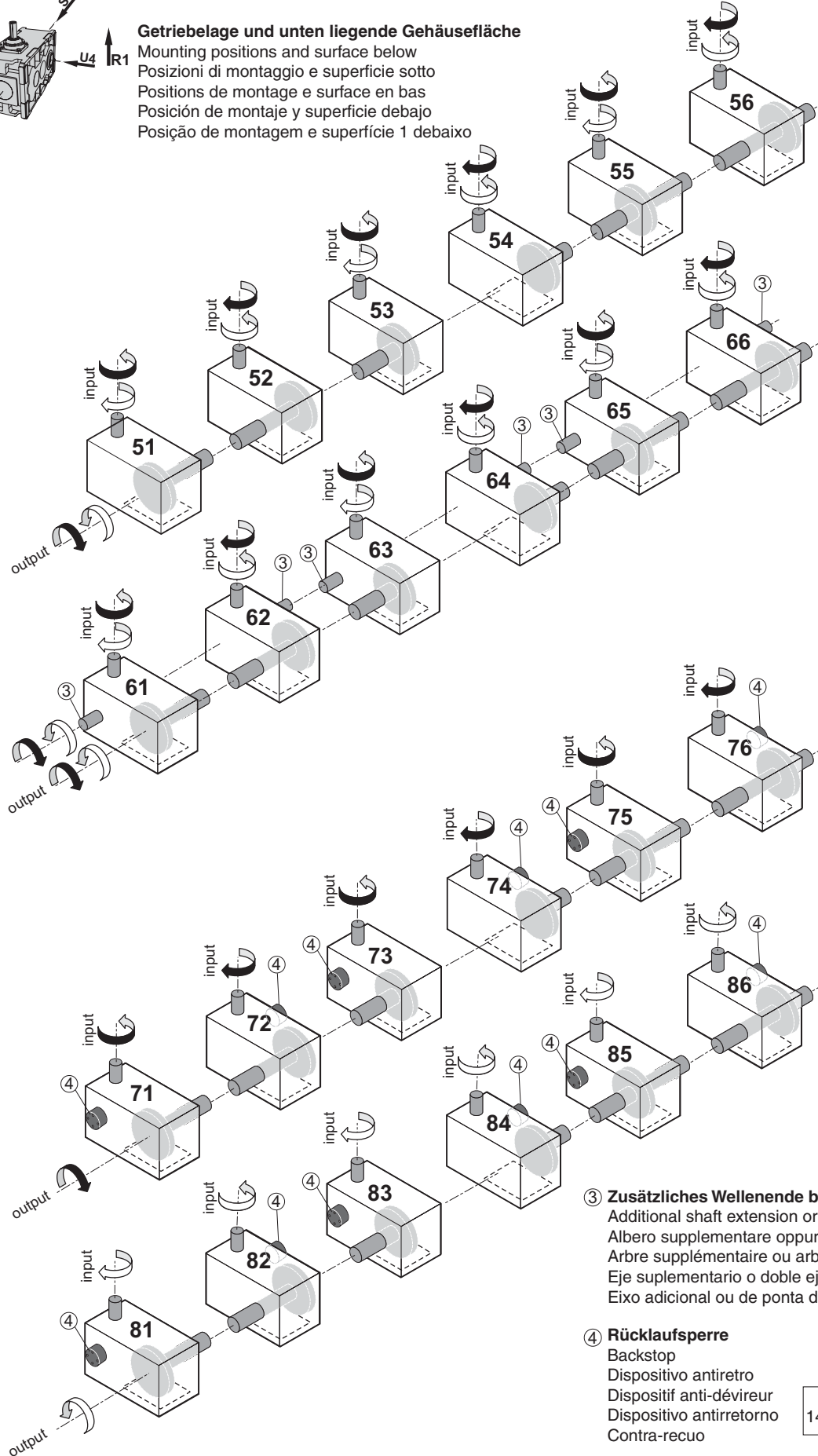

③ **Zusätzliches Wellenende bzw. durchgehende Welle**  
 Additional shaft extension or double extended shaft  
 Albero supplementare oppure bisporgente  
 Arbre supplémentaire ou arbre traversant  
 Eje suplementario o doble eje  
 Eixo adicional ou de ponta dupla

136

④ **Rücklaufsperre**  
 Backstop  
 Dispositivo antiretro  
 Dispositif anti-dévoreur  
 Dispositivo antirretorno  
 Contra-recuo

141

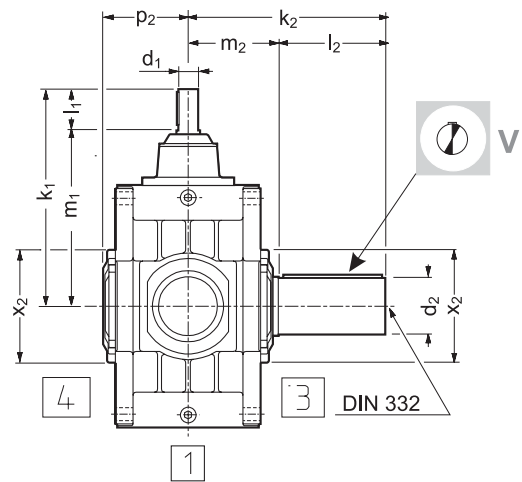
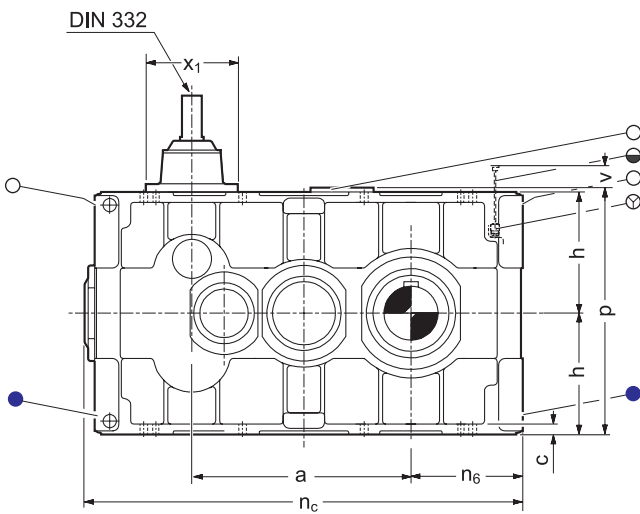
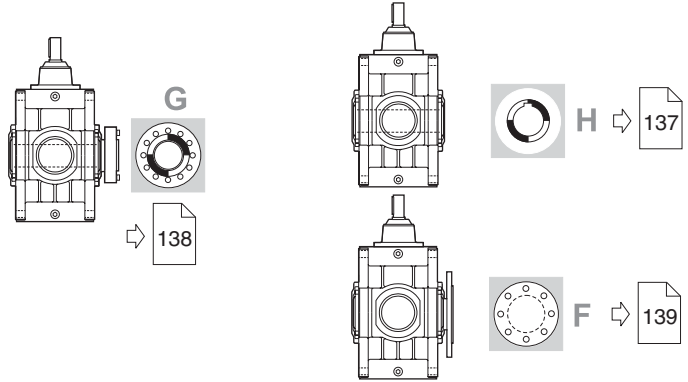
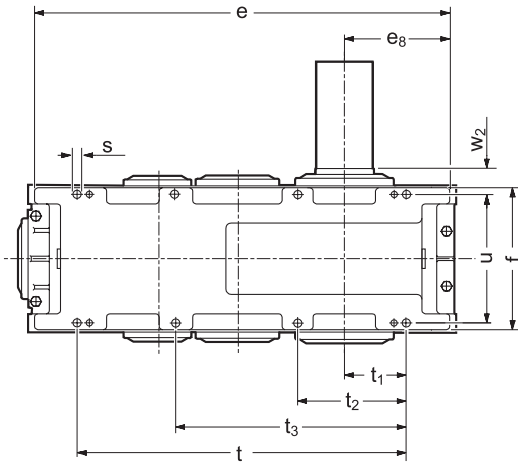
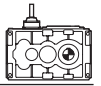

	Antriebswelle / Input shaft / Albero entrata Arbre d'entrée / Eje de entrada / Eixo de entrada					Abtriebswelle / Output shaft / Albero uscita Arbre de sortie / Eje de salida / Eixo de saída				
	Ø d <sub>1</sub> k6	k <sub>1</sub>	l <sub>1</sub>	m <sub>1</sub>	Ø x <sub>1</sub>	Ø d <sub>2</sub> m6	k <sub>2</sub>	l <sub>2</sub>	m <sub>2</sub>	Ø x <sub>2</sub>
PWD 14	20	319	80	239	132	65	270	135	135	-
PWD 16	20	319	80	239	132	85	290	145	145	-
PWD 18	25	378	85	293	148	95	350	170	180	-
PWD 20	25	387	85	302	148	120	370	190	180	-
PWD 22	40	497	120	377	190	130	405	190	215	-
PWD 25	40	482	120	362	190	145	450	230	220	296
PWD 28	40	497	120	377	190	160	480	230	250	328
PWD 31	40	497	120	377	190	175	540	290	250	348
PWD 35	50	517	120	397	285	155	570	290	280	328
PWD 40	50	593	120	473	285	175	570	290	280	348
PWD 42	60 m6	662	145	517	265	195	650	330	320	400
PWD 45	60 m6	666	145	521	265	210	730	410	320	440
PWD 47	60 m6	707	145	562	265	230	730	410	320	440
PWD 50	75 m6	769	160	609	285	250	795	410	385	480
PWD 53	75 m6	769	160	609	285	250	795	410	385	480
PWD 56	75 m6	844	160	684	285	270	845	460	385	540
PWD 60	85 m6	937	180	757	350	290	920	460	460	540
PWD 63	85 m6	937	180	757	350	310	970	510	460	580
PWD 67	85 m6	932	180	752	350	310	970	510	460	580
PWD 71 ... PWD 85	<b>Auf Anfrage / On request / A richiesta / Sur demande / Bajo demanda / Sob consulta</b>									



	Gehäuse / Casing / Carcassa / Carter / Carcasa / Carcaça									
	a	c	e	e <sub>s</sub>	f	h -0.2	n <sub>c</sub>	n <sub>6</sub>	p	p <sub>2</sub>
PWD 14	262	15	474	121	216	150	500	134	333	–
PWD 16	318	15	579	170	216	180	605	183	393	–
PWD 18	366	18	622	155	284	190	654	171	419	–
PWD 20	410	18	732	211	284	225	764	227	489	–
PWD 22	464	24	782	193	346	235	826	215	513	–
PWD 25	535	24	896	249	346	265	940	271	573	204
PWD 28	585	28	948	230	408	280	1000	256	610	246
PWD 31	653	28	1085	299	408	315	1137	325	680	239
PWD 35	726	32	1275	325	438	300	1346	345	610	262
PWD 40	736	32	1430	403	438	375	1501	423	760	262
PWD 42	837	40	1555	392	514	355	1652	422	720	303
PWD 45	899	40	1689	460	514	425	1786	490	860	303
PWD 47	924	40	1860	545	514	500	1957	575	1010	303
PWD 50	1070	50	1892	470	620	425	1962	505	860	358
PWD 53	1141	50	2038	545	620	500	2108	580	1010	358
PWD 56	1166	50	2231	645	620	600	2301	680	1210	365
PWD 60	1278	60	2272	565	770	530	2342	600	1070	440
PWD 63	1351	60	2420	640	770	600	2490	675	1210	440
PWD 67	1426	60	2566	715	770	670	2636	750	1350	440
PWD 71 ... PWD 85	<b>Auf Anfrage / On request / A richiesta / Sur demande / Bajo demanda / Sob consulta</b>									

	Befestigung / Fitting / Fissaggio / Fixation / Fijación / Fixação									OIL [l]	Kg
	Ø s	d <sub>s</sub> x l <sub>max</sub>	t	t <sub>1</sub>	t <sub>2</sub>	t <sub>3</sub>	u	w <sub>2</sub>	v		
PWD 14	12	M10x45	348	58	125	–	192	39	–	9	105
PWD 16	12	M10x80	453	107	217	–	192	49	20	10	170
PWD 18	14,5	M12x55	486	87	175	–	248	56	–	22	245
PWD 20	14,5	M12x90	596	143	285	–	248	56	–	27	335
PWD 22	18,5	M16x65	622	113	226	–	306	62	–	41	465
PWD 25	18,5	M16x90	736	169	340	–	306	67	–	51	600
PWD 28	24	M20x80	752	132	265	–	360	70	–	71	770
PWD 31	24	M20x110	889	201	402	–	360	70	–	93	1060
PWD 35	24	M20x85	1005	190	325	695	396	82	190	60	1500
PWD 40	24	M20x120	1157	265	477	847	396	82	220	80	1830
PWD 42	28	M24x100	1230	225	390	820	460	90	250	100	2200
PWD 45	28	M24x120	1356	285	516	946	460	90	250	140	2750
PWD 47	28	M24x250	1527	370	687	1117	460	90	250	190	3300
PWD 50	35	M30x120	1524	280	504	1014	560	105	250	200	4200
PWD 53	35	M30x180	1670	355	650	1160	560	105	250	260	4800
PWD 56	35	M30x250	1858	450	838	1348	560	105	250	360	5850
PWD 60	42	M36x150	1840	345	630	1200	690	115	350	380	7350
PWD 63	42	M36x200	1988	420	778	1348	690	115	350	480	8350
PWD 67	42	M36x250	2134	495	924	1494	690	115	350	580	9400
PWD 71 ... PWD 85	<b>Auf Anfrage / On request / A richiesta / Sur demande / Bajo demanda / Sob consulta</b>										

**Zusatzschmierung erforderlich, bitte rückfragen.**

Additional lubrication required, please check back.

Lubrificazione aggiuntiva necessaria, prego contattarci.

Lubrification supplémentaire à prévoir, demandez s.v.p.

Lubrificación adicional necesaria, pidanos informes.

Lubrificação adicional necessária, pedimos informar-nos.

**Maße l., m., und w. für fettgeschmierte Labyrinthdichtungen auf Anfrage.**

Dimensions l., m. and w. for grease lubricated labyrinth seals, on request.

Dimensioni l., m. e w. per tenute a labirinto con grasso a richiesta.

Dimensions l., m., et w. pour joints à labyrinthe lubrifiés à la graisse, sur demande.

Dimensiones l., m. y w. en caso de juntas laberínticas lubricadas con grasa, bajo demanda.

Dimensões l., m. e w. Em caso de juntas de anel labirinto lubrificado à graxa, sob consulta.