

Serie / Series / Serie / Série / Serie / Série

RRWD

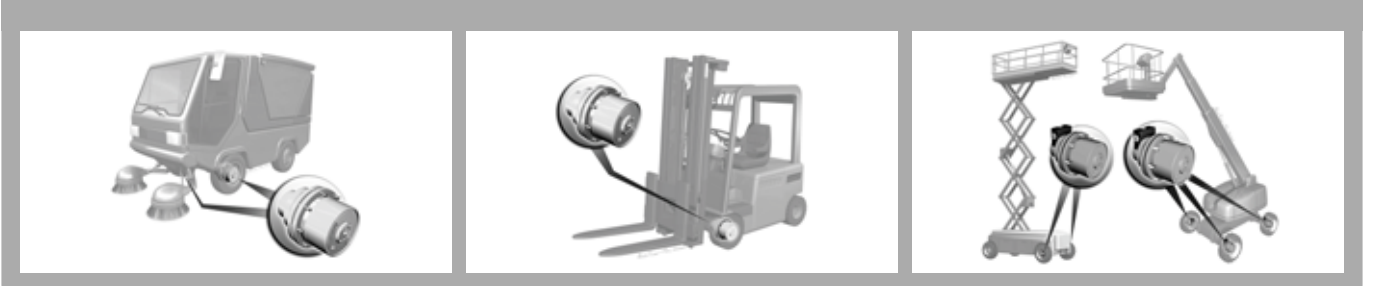

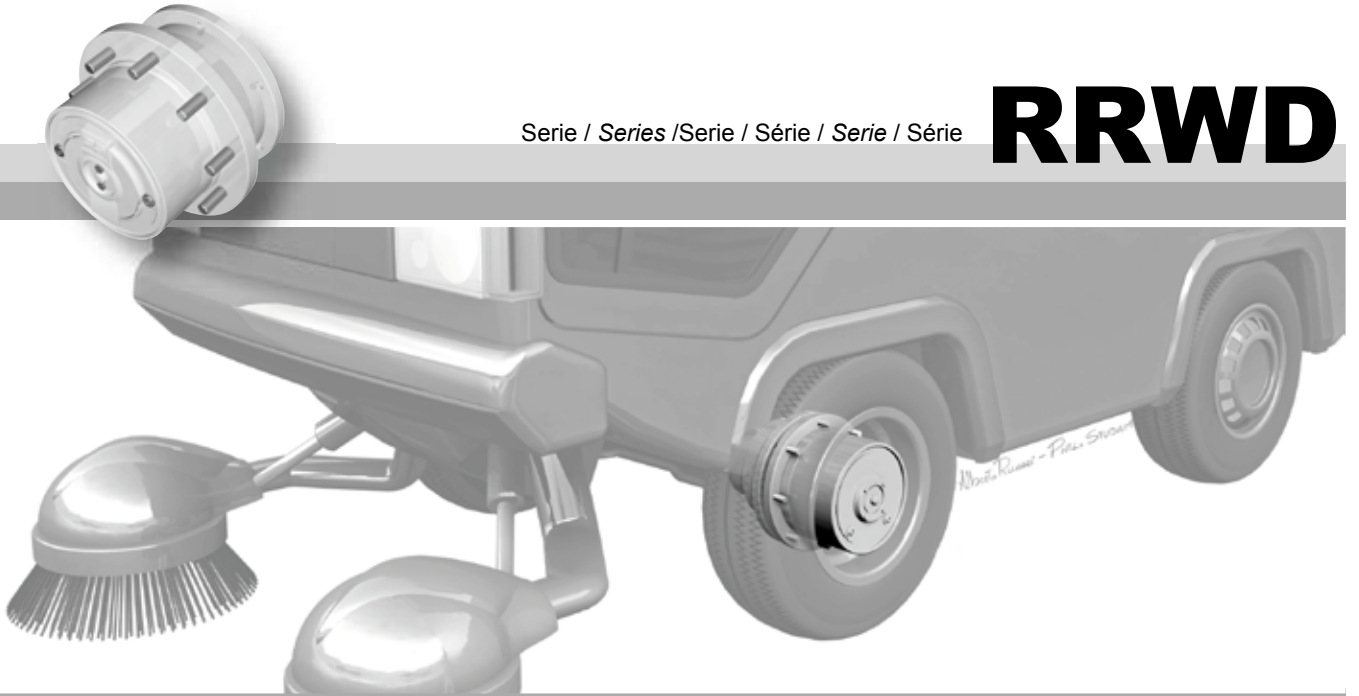

RRWD 200 - RRWD 200B

IT EN DE FR ES PT

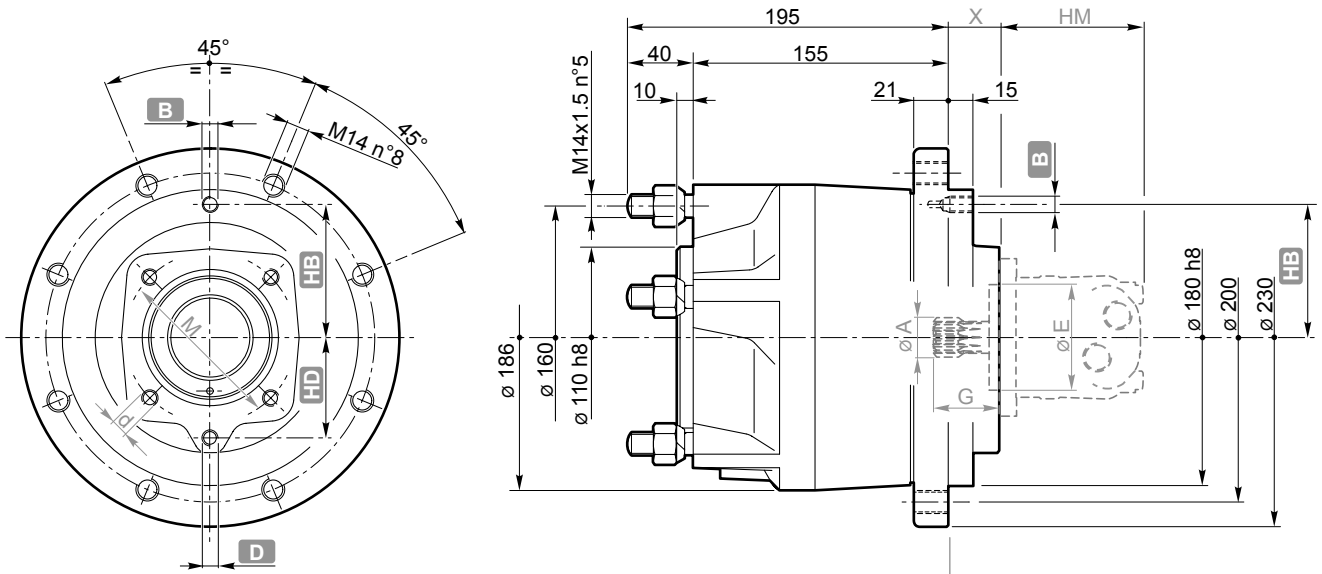

B	1/8"G
HB	81
D	1/8"G
HD	61

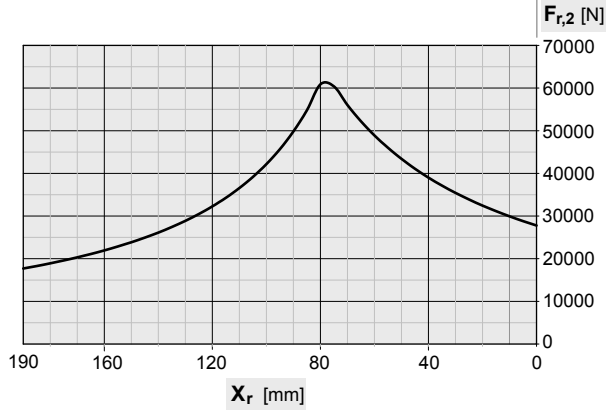

Dati freno/ Brake data
Bremsendaten/ Données frein
Datos freno / Dados do travão

RRWD 200B			
i	T _{F,1}	P _{amin}	P _{amax}
[-]	[Nm]	[bar]	[bar]
6.09	320	17-24	250

PAM		A	E	M	G	d	HM	X
1	S-D OMSU 3	DP 12/24 z12	75	104	46	M10 n°4	105±119	31
2	S-D OMP-OMR	1" SAE 6B	82.55	106.4	55.3	M12 n°2	141±157	29

	i	T ₂	T _{2max}	n _{1max}	m	V ₀
	[-]	[Nm]	[Nm]	[min ⁻¹]	[kg]	[l]
RRWD 200	6.09	900	2000	900	28	0.4
RRWD 200B		900	2000	900	29	0.3

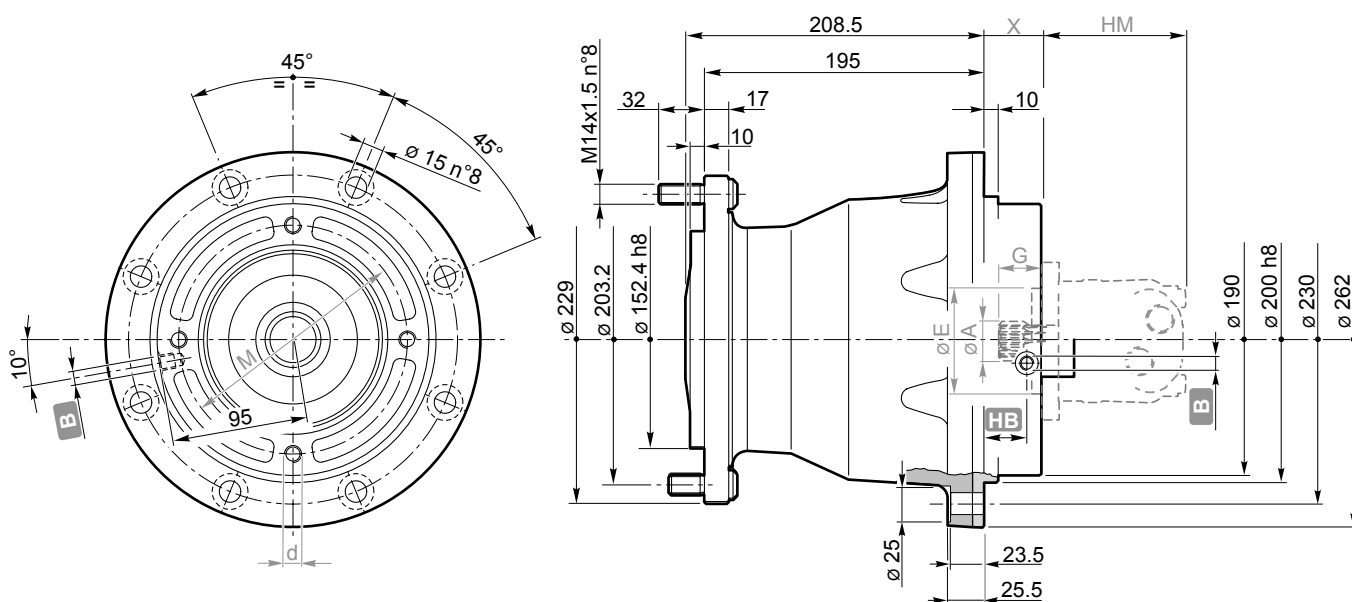
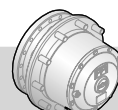

B	1/8"G
HB	30

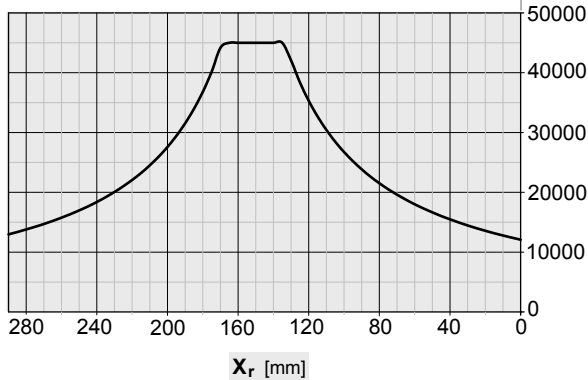

Dati freno/ Brake data
Bremsendaten/ Données frein
Datos freno / Dados do travão

RRWD 270B			
i	T _{F,1}	P _{amin}	P _{amax}
[-]	[Nm]	[bar]	[bar]
5.78	470	13-18	50
5.78	380	10-14	50

PAM		A	E	M	G	d	HM	X
5	S-D OMTS	DP 12/24 z16	125	160	46	M12 n°4	146+191	40

	i	T ₂	T _{2max}	n _{1max}	m	V ₀
	[-]	[Nm]	[Nm]	[min ⁻¹]	[kg]	[l]
RRWD 270	5.78	1510	2500	800	43.0	0.7
RRWD 270B		1510	2500	800	44.5	0.5