

RIDUTTORI EPICICLOIDALI P

PLANETARY GEAR UNITS P

K

	Indice	Index	Pag. Page
	Informazioni generali	<i>General technical information</i>	K2
	Configurazioni disponibili	<i>Available versions</i>	K3
P42	Dati tecnici	<i>Technical data</i>	K4
	Istruzioni per il montaggio	<i>Fitting instructions</i>	K4
	Dimensioni	<i>Dimensions</i>	K5
P52	Dati tecnici	<i>Technical data</i>	K6
	Istruzioni per il montaggio	<i>Fitting instructions</i>	K6
	Dimensioni	<i>Dimensions</i>	K7
P62	Dati tecnici	<i>Technical data</i>	K8
	Istruzioni per il montaggio	<i>Fitting instructions</i>	K8
	Dimensioni	<i>Dimensions</i>	K9
P72	Dati tecnici	<i>Technical data</i>	K10
	Istruzioni per il montaggio	<i>Fitting instructions</i>	K10
	Dimensioni	<i>Dimensions</i>	K11
P81	Dati tecnici	<i>Technical data</i>	K12
	Istruzioni per il montaggio	<i>Fitting instructions</i>	K12
	Dimensioni	<i>Dimensions</i>	K13
P105	Dati tecnici	<i>Technical data</i>	K14
	Istruzioni per il montaggio	<i>Fitting instructions</i>	K14
	Dimensioni	<i>Dimensions</i>	K15
P120	Dati tecnici	<i>Technical data</i>	K16
	Istruzioni per il montaggio	<i>Fitting instructions</i>	K16
	Dimensioni	<i>Dimensions</i>	K17
	Opzioni	<i>Options</i>	K18

Informazioni generali

General technical information

Caratteristiche dei riduttori epicicloidali

- Ingresso ed uscita coassiali
- Design compatto
- Alte coppie in ingombri ridotti
- Momenti di inerzia ridotti
- Adatto per servizio continuo ed intermittente
- Possono essere installati in qualsiasi posizione di montaggio

Vasta gamma di rapporti di riduzione

Quattro diverse coppie di ingranaggi centrali e satelliti forniscono parecchie riduzioni per ogni stadio del riduttore.

Il disegno modulare fornisce un totale di 72 **riduzioni da $i=3.7:1$ a $i=2076:1$, in quattro stadi.**

Non tutte le riduzioni sono numeri interi.

Durata in servizio

La durata in servizio dipende in gran parte dalle condizioni ambientali e dal suo utilizzo. È possibile scegliere il riduttore adatto ad eseguire operazioni continue tenendo conto dei fattori rilevanti. Per applicazioni con tempi brevi o ad alta intermittenza consultare i nostri esperti.

Dinamiche operative

La distribuzione bilanciata del carico negli ingranaggi e una notevole riduzione della rotazione delle parti assicurano momenti di inerzia molto ridotti. La distribuzione bilanciata del carico viene raggiunta ottimizzando la forma dei denti e monitorando continuamente la qualità della produzione.

Lubrificazione permanente

I riduttori epicicloidali sono lubrificati in modo permanente conformemente alle prestazioni richieste, non richiedono quindi ulteriore manutenzione. Questo gli consente di essere installati praticamente ovunque.

La temperatura di ogni riduttore viene elencata in un foglio di specifiche tecniche.

Per applicazioni particolari, possono essere adottate misure per raggiungere livelli di temperatura maggiori.

Flange di raccordo

Tutte le serie sono disponibili come standard nelle versioni base. Le serie che vanno dalla P 52 alla P 120 sono inoltre disponibili con flange standard per DIN 42948 (metrica standard per serie di motori), sia sui motori che sul lato di uscita. Le flange di raccordo possono anche essere fornite per motori speciali non standard. In tutte le dimensioni, il pignone in ingresso è fissato direttamente all'albero motore. Se i volumi lo giustificano, i denti dell'ingranaggio possono essere lavorati direttamente sull'albero motore (previo accordo del produttore del motore) e la flangia del motore può essere adattata per accoppiarsi con la nostra flangia del riduttore. In questo modo si ottiene una lunghezza totale inferiore e un sistema con un rapporto qualità-prezzo superiore.

Le richieste specifiche dei singoli clienti possono essere adattate a tutte le dimensioni (sia per quanto riguarda il lato motore che per il lato di uscita).

Characteristics of planetary gear units

- Coaxial arrangement of the input and output
- Compact design
- Advantageous torque with minimum space requirements
- Low moments of inertia
- Suitable for continuous, reversing and intermittent operation
- Can be installed in any mounting position

Large range of ratios

Four different pairings of sun gear and planets provide many ratios per gearbox stage.

The modular design provides a total of 72 **reduction ratios from $i=3.7: 1$ to $i= 2076:1$, in four stages.**

Not all reduction ratios are not whole numbers.

Service life

Service life largely depends upon the ambient conditions and operating requirements.

The correct gear unit for continuous operation can be selected by taking the relevant factors into consideration. For short term or highly intermittent applications consult our experts

Operating dynamics

The balanced load distribution of the planet gears and a minimisation of the rotating parts ensure low moments of inertia. Balanced load distribution is achieved by a optimising the tooth form and by a continuous monitoring of the manufacturing quality

Life-time lubrication

Planetary gearboxes are life-time lubricated with grease in line with their expected performance, and therefore they are maintenance-free.

This allows them to be installed practically in any location.

The temperature range of each gear unit size is listed in the technical specification sheet.

For special applications, measures can be taken for higher temperature ranges

Connecting flanges

All series are available as standard in the basic version.

Series P 52 to P 120 are available additionally with standard flanges to DIN 42948 (standard metric series motors) on the motor and output side.

Adaptor flanges can also be supplied for special or non-standard motors.

In all sizes, the motor pinion is fastened directly to the motor shaft. If quantity justify, the gear teeth can be cut directly to the motor shaft (with the motor manufacturer's agreement) and the motor end shield adapted to the gear flange.

In this way, a shorter overall length and a more cost effective system are achieved.

Specific customer requirements can be arranged in all sizes (on both the motor and output side).

P42

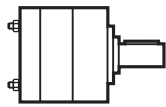

$i: 4-308$
 $Nm: 15$

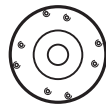

Flangia uscita
Output flange

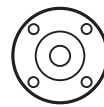

Flangia entrata
Input flange

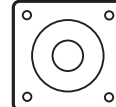

P52

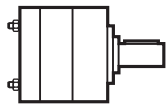

$i: 4-308$
 $Nm: 25$

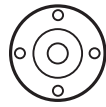

Flangia uscita
Output flange

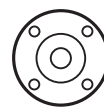

Flangia entrata
Input flange

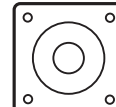

P62

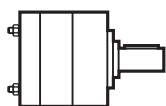

$i: 4-308$
 $Nm: 50$

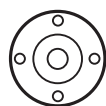

Flangia uscita
Output flange

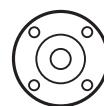

Flangia entrata
Input flange

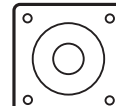

P72

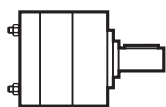

$i: 4-308$
 $Nm: 84$

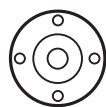

Flangia uscita
Output flange

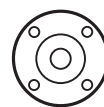

Flangia entrata
Input flange

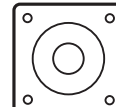

P81

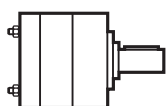

$i: 4-308$
 $Nm: 120$

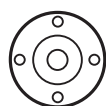

Flangia uscita
Output flange

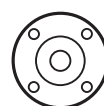

Flangia entrata
Input flange

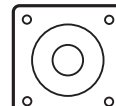

P105

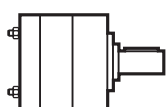

$i: 4-308$
 $Nm: 195$

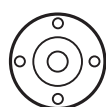

Flangia uscita
Output flange

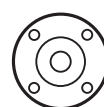

Flangia entrata
Input flange

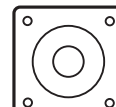

P120

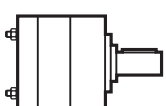

$i: 4-308$
 $Nm: 300$

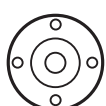

Flangia uscita
Output flange

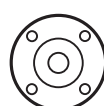

Flangia entrata
Input flange

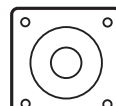

Opzioni/Options

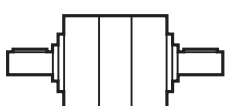

Dati tecnici

Technical data

Lubrificazione

Grasso (lubrificazione permanente)

Lubrication

Grease (life-time lubrication)

Senso di rotazione

Uguale per albero in ingresso e in uscita

Direction of rotation

Same for input and output shaft

Temperatura di funzionamento consentita

da -30 °C a +140 °C

Operating temperature range

from -30 °C to +140 °C

Velocità nominale in ingresso: 3000 min⁻¹

Input rated speed: 3000 min⁻¹

Simbologia / Symbols

Ns	n° stadi No. stages
in	rapporto nominale nominal ratio
ir	rapporto reale real ratio
J [gcm ²]	momento d'inerzia riferito all'albero di entrata moment of inertia referred to input shaft
M ₂ [Nm]	coppia in uscita in funzionamento continuativo S1 output torque for continuous operation S1
Rd	rendimento dinamico efficiency
R ₂ [N]	massimo carico radiale al centro dell'albero uscita max. radial load at output shaft centre
A ₂ [N]	massimo carico assiale max. axial load
Kg [Kg]	peso weight

Ns	in	ir	J [gcm ²]	M ₂ [Nm]	Rd	cuscinetto a sfere ball bearing		Kg
						R ₂ [N]	A ₂ [N]	
1	4	3.70	4.68	3	0.80	160	50	0.4
	4	4.28	3.80					
	5	5.18	3.08					
	7	6.75	2.35					
2	14	13.73	4.41	7.5	0.75	230	80	0.5
	16	15.88	3.59					
	18	18.36	3.58					
	19	19.20	2.93					
	22	22.20	2.92					
	25	25.01	2.26					
	27	26.85	2.91					
	29	28.93	2.25					
	35	34.97	2.25					
	46	45.56	2.25					
3	51	50.89	4.41	15	0.70	300	110	0.6
	59	58.85	3.59					
	68	68.06	3.58					
	71	71.16	2.93					
	79	78.71	3.58					
	93	92.70	2.26					
	95	95.17	2.92					
	100	99.50	2.91					
	107	107.20	2.25					
	115	115.07	2.91					
	124	123.97	2.25					
	130	129.62	2.25					
	139	139.13	2.91					
	150	149.90	2.25					
169	168.84	2.25						
181	181.24	2.25						
195	195.26	2.25						
236	236.09	2.25						
308	307.54	2.25						

Rapporti preferenziali / Preferred ratios

Disponibile 4 stadi con rapporti fino a 2076 / Available 4 stages with ratio up to 2076

Istruzioni per il montaggio

Attenersi alle seguenti condizioni di montaggio nel determinare le flange di connessione:

Fitting instructions

Please take note of the following mounting conditions when determining the connecting flanges:

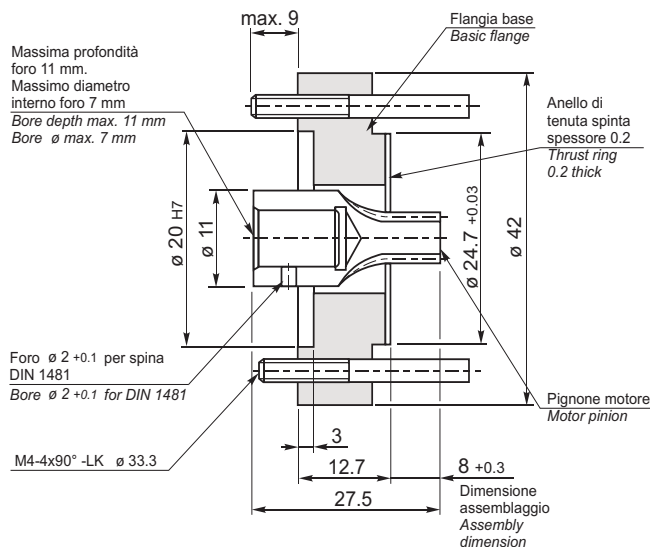

Opzione

Disponibile anche nella versione con serraggio mediante morsetto elastico equilibrato.

Options

Also available with clamp-fixing system.

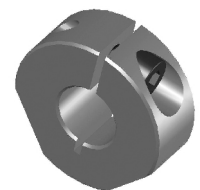

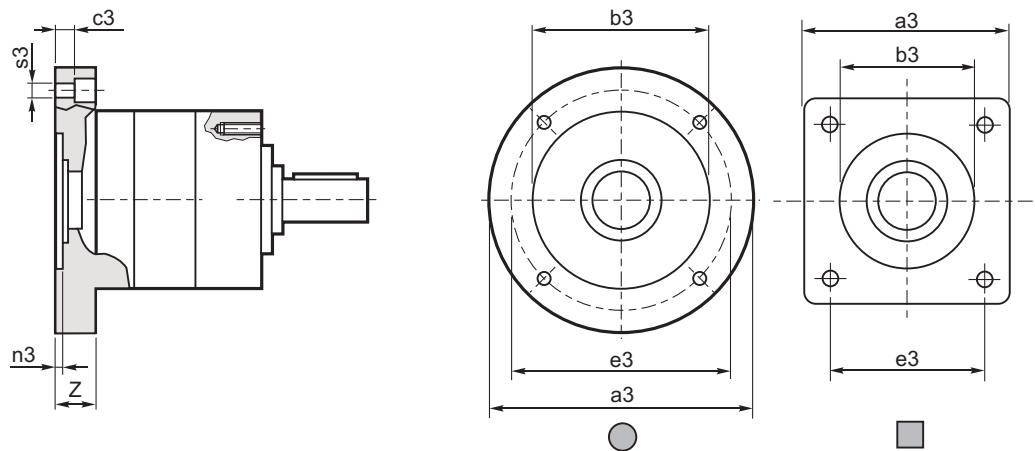
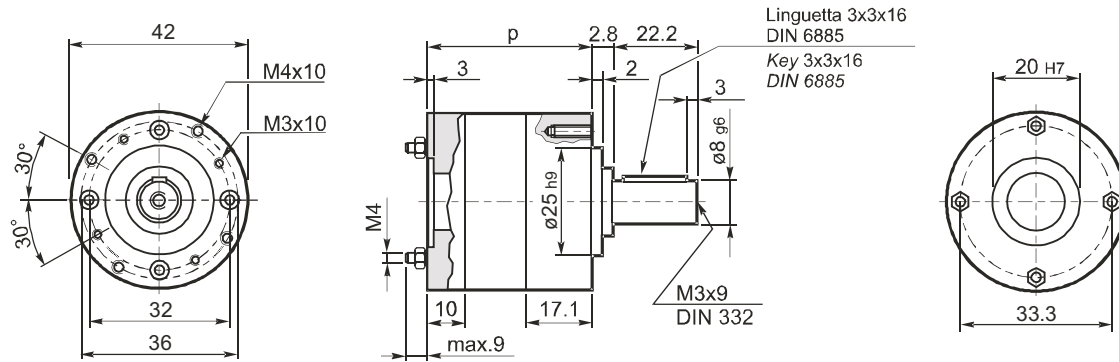

Lunghezza riduttore Gearbox length	p	N° stadi / No. stages		
		1	2	3
		49	62	75

Dimensioni flangia motore Motor flange dimensions	AS 05	AS 11	AS 32	AS 130	a_3	b_3	c_3	e_3	n_3	s_3	Z
					■	42	22 H7	17	31	2	3.5
■	56	38.1 H7	—	47.14	2	M4	17				
●	42	22 H7	16.5	32	3	3.5	11.5				

Flange entrata/uscita speciali a richiesta del cliente
Special input/output flanges for specific customer requirements

Dati tecnici

Technical data

Lubrificazione

Grasso (lubrificazione permanente)

Lubrication

Grease (life-time lubrication)

Senso di rotazione

Uguale per albero in ingresso e in uscita

Direction of rotation

Same for input and output shaft

Temperatura di funzionamento consentita

da -30 °C a +140 °C

Operating temperature range

from -30 °C to +140 °C

Velocità nominale in ingresso: 3000 min⁻¹

Input rated speed: 3000 min⁻¹

Simbologia / Symbols

Ns	n° stadi No. stages
in	rapporto nominale nominal ratio
ir	rapporto reale real ratio
J [gcm ²]	momento d'inerzia riferito all'albero di entrata moment of inertia referred to input shaft
M ₂ [Nm]	coppia in uscita in funzionamento continuativo S1 output torque for continuous operation S1
Rd	rendimento dinamico efficiency
R ₂ [N]	massimo carico radiale al centro dell'albero uscita max. radial load at output shaft centre
A ₂ [N]	massimo carico assiale max. axial load
Kg [Kg]	peso weight

Ns	in	ir	J [gcm ²]	M ₂ [Nm]	Rd	cuscinetto a sfere ball bearing		Kg
						R ₂ [N]	A ₂ [N]	
1	4	3.70	18.35	4	0.80	200	60	0.7
	4	4.28	15.36					
	5	5.18	12.33					
	7	6.75	11.32					
2	14	13.73	17.11	12	0.75	320	100	0.9
	16	15.88	14.41					
	18	18.36	14.36					
	19	19.20	11.66					
	22	22.20	11.63					
	25	25.01	9.50					
	27	26.85	11.61					
	29	28.93	9.48					
3	35	34.97	9.47	25	0.70	450	150	1.1
	46	45.56	9.47					
	51	50.89	17.11					
	59	58.85	14.41					
	68	68.06	14.36					
	71	71.16	11.66					
	79	78.71	14.36					
	93	92.70	11.61					
	95	95.17	14.36					
	100	99.50	11.61					
	107	107.20	9.48					
	115	115.07	11.61					
	124	123.97	9.48					
	130	129.62	9.47					
139	139.13	11.61						
150	149.90	9.47						
169	168.84	9.47						
181	181.24	9.47						
195	195.26	9.47						
236	236.09	9.47						
308	307.54	9.47						

Rapporti preferenziali / Preferred ratios

Disponibile 4 stadi con rapporti fino a 2076 / Available 4 stages with ratio up to 2076

Istruzioni per il montaggio

Attenersi alle seguenti condizioni di montaggio nel determinare le flange di connessione:

Fitting instructions

Please take note of the following mounting conditions when determining the connecting flanges:

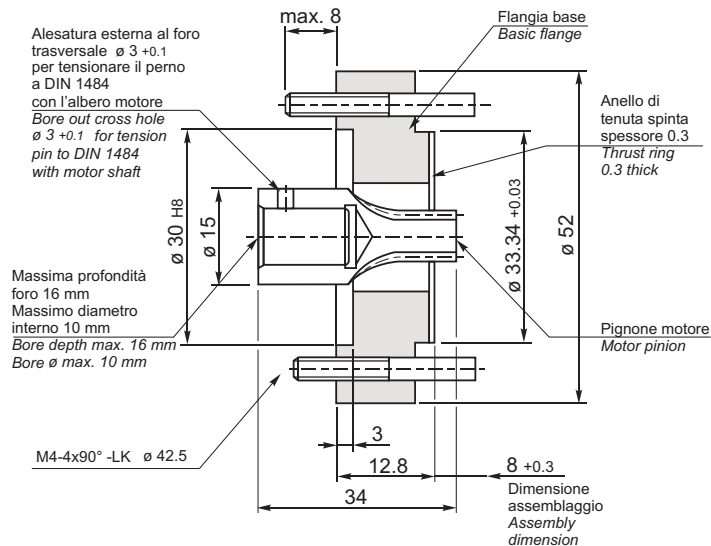

Opzione

Disponibile anche nella versione con serraggio mediante morsetto elastico equilibrato.

Options

Also available with clamp-fixing system.

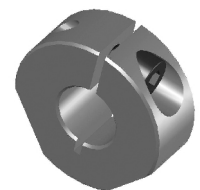

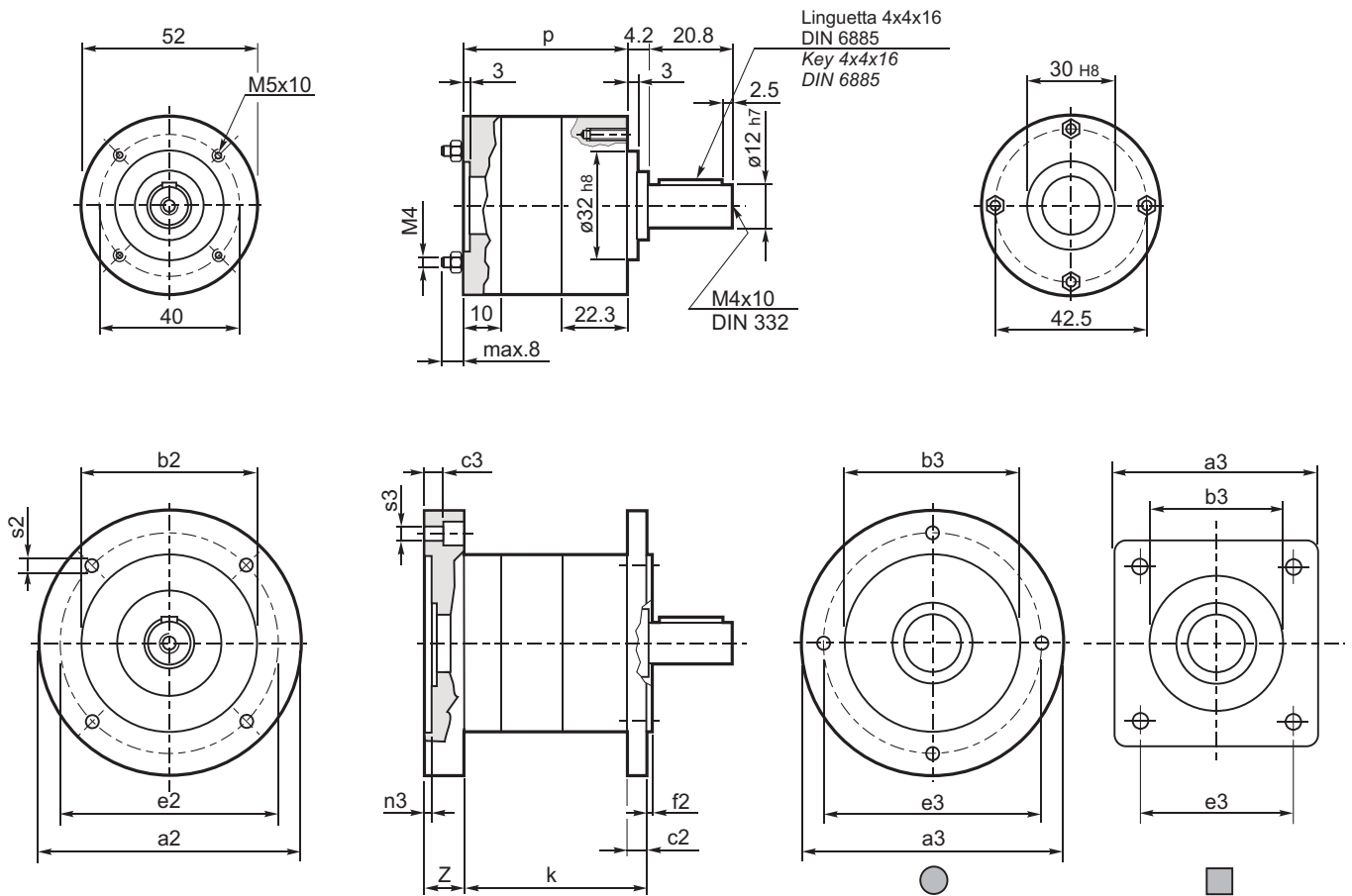

Lunghezza riduttore Gearbox length		N° stadi / No. stages		
		1	2	3
	p	56	70	84
	k	65	79	93

Dimensioni flangia motore Motor flange dimensions		a3	b3	c3	e3	n3	s3	Z
		● C 80	80	50 H7	10.2	65	3	5.5
● C 105	105	70 H7	10.2	85	3	6.5	18	
■ AS 07	56	38.10 H7	—	47.14	2	4.5	18	
■ AS 09	60	36 H7	—	50	2	M4	17	
● AS 23	60	26 H7	18.8	39	3	4.5	18	
● AS 60	79.5	50 H7	10.2	65	3	5.5	18	
	AS115							

Dimensioni flangia uscita riduttore Output flange dimensions		a2	b2	c2	e2	f2	s2
		C 80	80	50 j7	9	65	2.5
	C 90	90	60 j7	9	75	2.5	5.5
	C 105	105	70 j7	9	85	2.5	6.5
	C 120	120	80 j7	9	100	3.0	6.5

Flange entrata / uscita speciali a richiesta del cliente
Special input / output flanges for specific customer requirements

Dati tecnici

Technical data

Lubrificazione

Grasso (lubrificazione permanente)

Lubrication

Grease (life-time lubrication)

Senso di rotazione

Uguale per albero in ingresso e in uscita

Direction of rotation

Same for input and output shaft

Temperatura di funzionamento consentita

da -30 °C a +140 °C

Operating temperature range

from -30 °C to +140 °C

Velocità nominale in ingresso: 3000 min⁻¹

Input rated speed: 3000 min⁻¹

Simbologia / Symbols

Ns	n° stadi No. stages
in	rapporto nominale nominal ratio
ir	rapporto reale real ratio
J [gcm ²]	momento d'inerzia riferito all'albero di entrata moment of inertia referred to input shaft
M ₂ [Nm]	coppia in uscita in funzionamento continuativo S1 output torque for continuous operation S1
Rd	rendimento dinamico efficiency
R ₂ [N]	massimo carico radiale al centro dell'albero uscita max. radial load at output shaft centre
A ₂ [N]	massimo carico assiale max. axial load
Kg [Kg]	peso weight

Ns	in	ir	J [gcm ²]	M ₂ [Nm]	Rd	cuscinetto a sfere ball bearing		Kg
						R ₂ [N]	A ₂ [N]	
1	4	3.70	37	8	0.80	240	70	0.8
	4	4.28	29					
	5	5.18	23					
	7	6.75	17					
2	14	13.73	35	25	0.75	360	100	1.2
	16	15.88	28					
	18	18.36	28					
	19	19.20	22					
	22	22.20	22					
	25	25.01	17					
	27	26.85	22					
	29	28.93	17					
	35	34.97	17					
	46	45.56	17					
3	51	50.89	35	50	0.70	520	150	1.6
	59	58.85	28					
	68	68.06	28					
	71	71.16	21					
	79	78.71	28					
	93	92.70	16					
	95	95.17	22					
	100	99.50	22					
	107	107.20	17					
	115	115.07	22					
	124	123.97	17					
	130	129.62	17					
	139	139.13	22					
	150	149.90	17					
169	168.84	17						
181	181.24	17						
195	195.26	17						
236	236.09	17						
308	307.54	17						

Rapporti preferenziali / Preferred ratios

Disponibile 4 stadi con rapporti fino a 2076 / Available 4 stages with ratio up to 2076

Istruzioni per il montaggio

Attenersi alle seguenti condizioni di montaggio nel determinare le flange di connessione:

Fitting instructions

Please take note of the following mounting conditions when determining the connecting flanges:

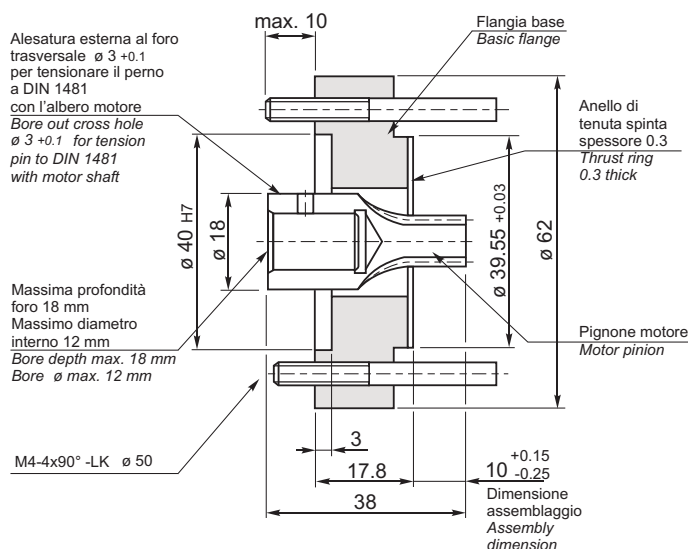

Opzione

Disponibile anche nella versione con serraggio mediante morsetto elastico equilibrato.

Options

Also available with clamp-fixing system.

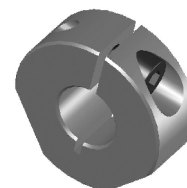

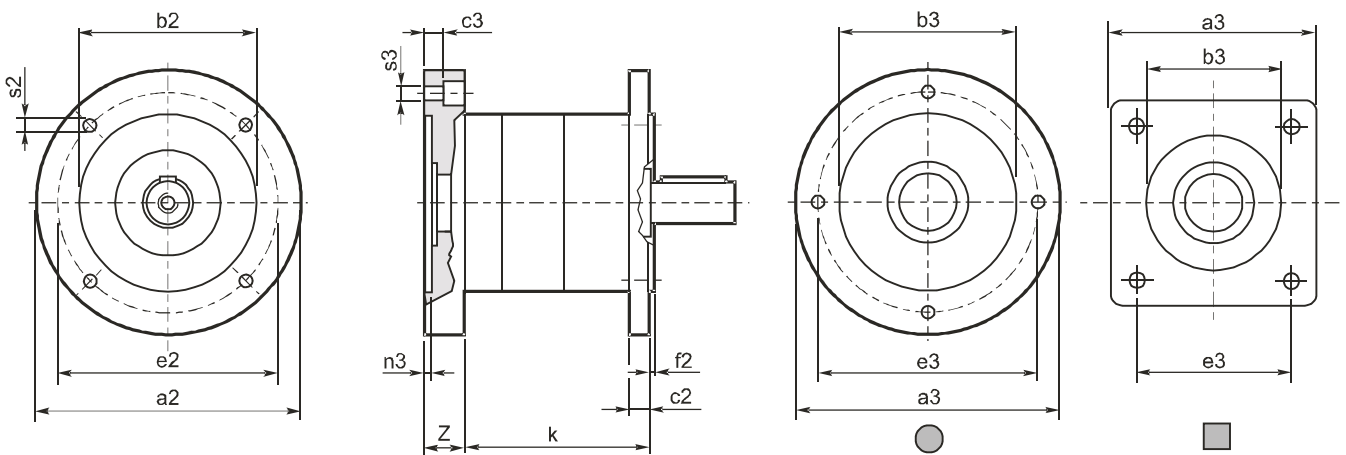
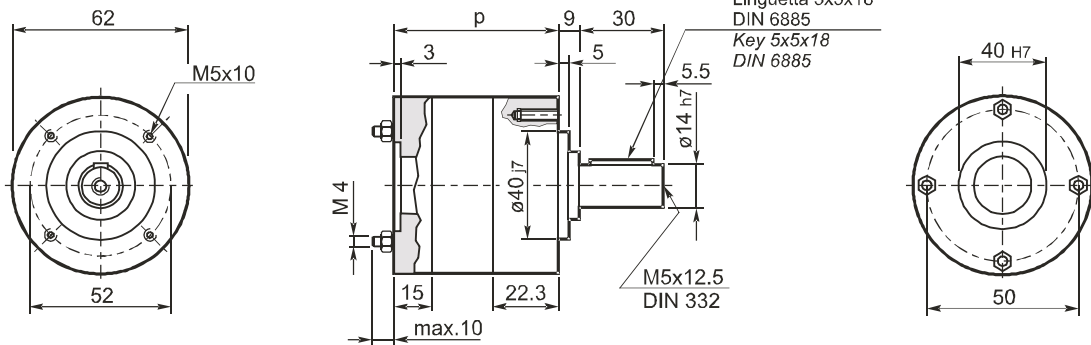

Lunghezza riduttore Gearbox length		N° stadi / No. stages		
		1	2	3
	p	61	77	93
	k	70	86	102

		a3	b3	c3	e3	n3	s3	Z
Dimensioni flangia motore Motor flange dimensions	● C 80	80	50 H7	7	65	3	5.5	15
	● C 90	90	60 H7	7	75	3	5.5	15
	● C 105	105	70 H7	7	85	3	6.5	15
	● C 120	120	80 H7	7	100	3.5	6.5	15
	■ AS 08	60	50 H7	—	49.5	4	M4	22
	■ AS 12	85	73.02 H7	—	69.6	2	M5	25
	■ AS 15	58	38.10 H7	—	47.14	2	M4	15
	● AS 61	89.5	60 H7	7	75	3	5.5	15

		a2	b2	c2	e2	f2	s2
Dimensioni flangia uscita riduttore Output flange dimensions	C 80	80	50 j7	9	65	2.5	M5
	C 90	90	60 j7	9	75	2.5	5.5
	C 105	105	70 j7	9	85	2.5	6.5
	C 120	120	80 j7	9	100	3.0	6.5

Flange entrata / uscita speciali a richiesta del cliente
Special input / output flanges for specific customer requirements

Dati tecnici

Technical data

Lubrificazione

Grasso (lubrificazione permanente)

Lubrication

Grease (life-time lubrication)

Senso di rotazione

Uguale per albero in ingresso e in uscita

Direction of rotation

Same for input and output shaft

Temperatura di funzionamento consentita

da -30 °C a +140 °C

Operating temperature range

from -30 °C to +140 °C

Velocità nominale in ingresso: 3000 min⁻¹

Input rated speed: 3000 min⁻¹

Simbologia / Symbols

Ns	n° stadi No. stages
in	rapporto nominale nominal ratio
ir	rapporto reale real ratio
M ₂ [Nm]	coppia in uscita in funzionamento continuativo S1 output torque for continuous operation S1
Rd	rendimento dinamico efficiency
R ₂ [N]	massimo carico radiale al centro dell'albero uscita max. radial load at output shaft centre
A ₂ [N]	massimo carico assiale max. axial load
Kg	peso weight

Ns	in	ir	M ₂ [Nm]	Rd	cuscinetto a sfere ball bearing		Kg
					R ₂ [N]	A ₂ [N]	
1	4	3.70	14	0.80	320	70	1.4
	4	4.28					
	5	5.18					
	7	6.75					
2	14	13.73	42	0.75	480	100	1.9
	16	15.88					
	18	18.36					
	19	19.20					
	22	22.20					
	25	25.01					
	27	26.85					
	29	28.93					
	35	34.97					
	46	45.56					
3	51	50.89	84	0.70	760	160	2.4
	59	58.85					
	68	68.06					
	71	71.16					
	79	78.71					
	93	92.70					
	95	95.17					
	100	99.50					
	107	107.20					
	115	115.07					
	124	123.97					
	130	129.62					
139	139.13						
150	149.90						
169	168.84						
181	181.24						
195	195.26						
236	236.09						
308	307.54						

Disponibile 4 stadi con rapporti fino a 2076 / Available 4 stages with ratio up to 2076

Istruzioni per il montaggio

Attenersi alle seguenti condizioni di montaggio nel determinare le flange di connessione:

Fitting instructions

Please take note of the following mounting conditions when determining the connecting flanges:

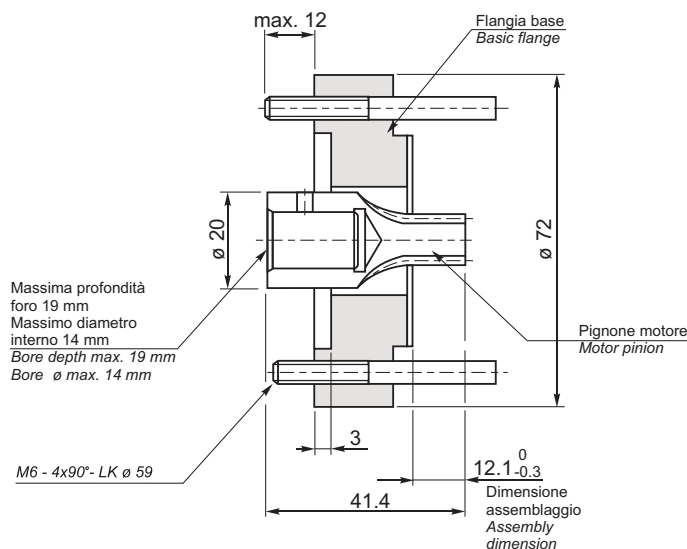

Opzione

Disponibile anche nella versione con serraggio mediante morsetto elastico equilibrato.

Options

Also available with clamp-fixing system.

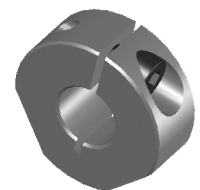

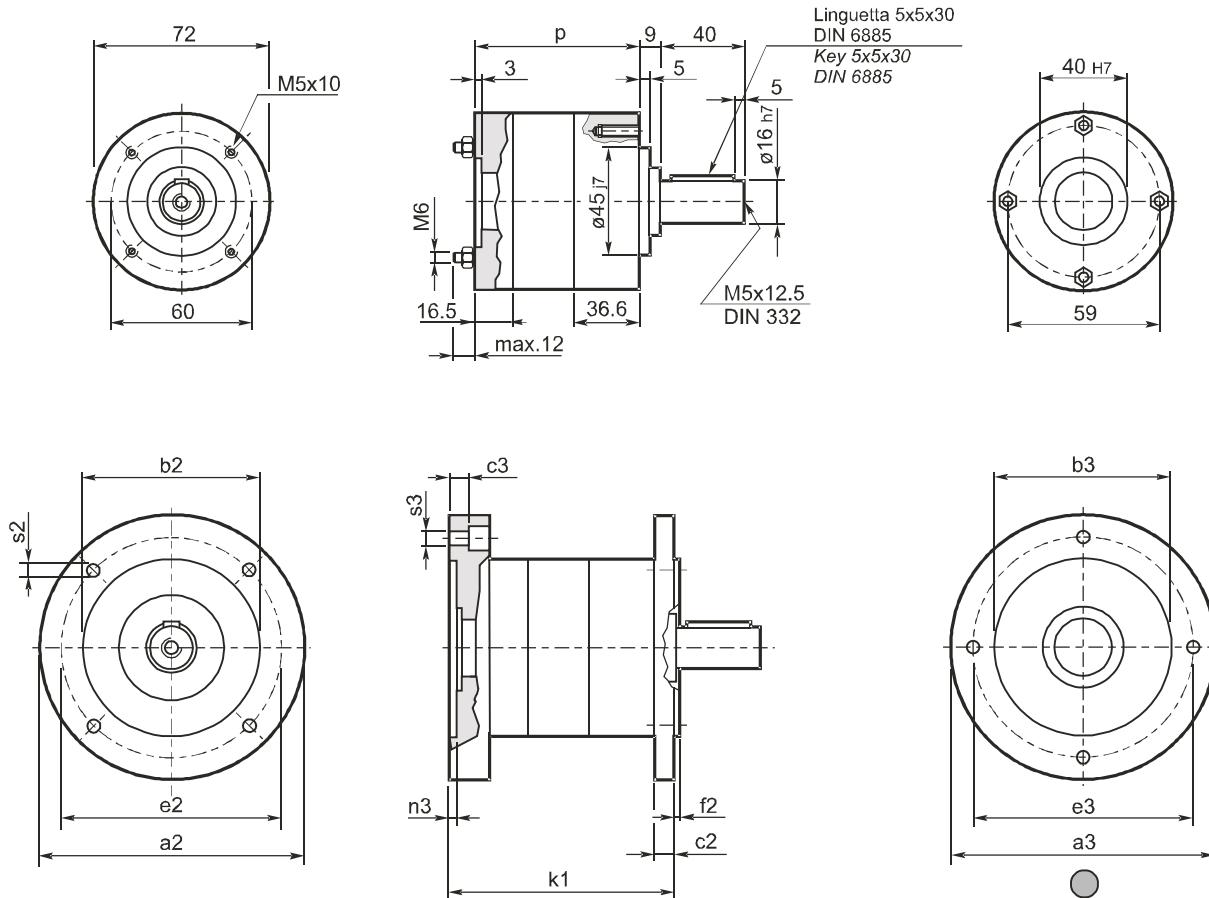

Lunghezza riduttore Gearbox length		N° stadi / No. stages		
		1	2	3
p		73.4	93	112.6
k1		94.6 (56-63)	114.2 (56-63)	133.8 (56-63)

		a3	b3	c3	e3	n3	s3
Dimensioni flangia motore Motor flange dimensions	● C 80	80	50 H7	9	65	3	5.5
	● C 90	90	60 H7	9	75	3	5.5
	● C 105	105	70 H7	9	85	3	6.5
	● C 120	120	80 H7	9	100	3.5	6.5

		a2	b2	c2	e2	f2	s2
Dimensioni flangia uscita riduttore Output flange dimensions	C 80	80	50 j7	9	65	2.5	M5
	C 90	90	60 j7	9	75	2.5	M5
	C 105	105	70 j7	9	85	2.5	6.5
	C 120	120	80 j7	9	100	3.0	6.5

Flange entrata / uscita speciali a richiesta del cliente
Special input / output flanges for specific customer requirements

Dati tecnici

Lubrificazione

Grasso (lubrificazione permanente)

Lubrication

Grease (life-time lubrication)

Senso di rotazione

Uguale per albero in ingresso e in uscita

Direction of rotation

Same for input and output shaft

Temperatura di funzionamento consentita

da -30 °C a +140 °C

Operating temperature range

from -30 °C to +140 °C

Velocità nominale in ingresso: 3000 min⁻¹

Input rated speed: 3000 min⁻¹

Simbologia / Symbols

Ns	n° stadi No. stages
in	rapporto nominale nominal ratio
ir	rapporto reale real ratio
J [gcm ²]	momento d'inerzia riferito all'albero di entrata moment of inertia referred to input shaft
M ₂ [Nm]	coppia in uscita in funzionamento continuo S1 output torque for continuous operation S1
Rd	rendimento dinamico efficiency
R ₂ [N]	massimo carico radiale al centro dell'albero uscita max. radial load at output shaft centre
A ₂ [N]	massimo carico assiale max. axial load
Kg [Kg]	peso weight

Technical data

Ns	in	ir	J [gcm ²]	M ₂ [Nm]	Rd	cuscinetto a sfere ball bearing		Kg
						R ₂ [N]	A ₂ [N]	
1	4	3.70	165	20	0.80	400	80	1.8
	4	4.28	134					
	5	5.18	109					
	7	6.75	91					
2	14	13.73	155	60	0.75	600	120	2.5
	16	15.88	127					
	18	18.36	129					
	19	19.20	100					
	22	22.20	105					
	25	25.01	125					
	27	26.85	105					
	29	28.93	88					
3	35	34.97	89	120	0.70	1000	200	3.2
	46	45.56	89					
	51	50.89	154					
	59	58.85	126					
	68	68.06	127					
	71	71.16	104					
	79	78.71	127					
	93	92.70	88					
	95	95.17	104					
	100	99.50	105					
	107	107.20	88					
	115	115.07	105					
124	123.97	88						
130	129.62	88						
139	139.13	102						
150	149.90	88						
169	168.84	89						
181	181.24	88						
195	195.26	89						
236	236.09	89						
308	307.54	89						

Rapporti preferenziali / Preferred ratios

Disponibile 4 stadi con rapporti fino a 2076 / Available 4 stages with ratio up to 2076

Istruzioni per il montaggio

Attenersi alle seguenti condizioni di montaggio nel determinare le flange di connessione:

Fitting instructions

Please take note of the following mounting conditions when determining the connecting flanges:

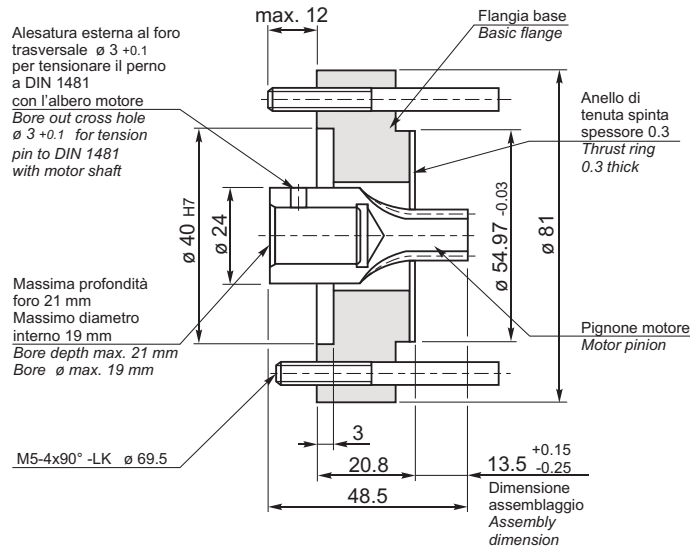

Opzione

Disponibile anche nella versione con serraggio mediante morsetto elastico equilibrato.

Options

Also available with clamp-fixing system.

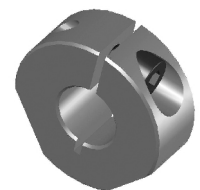

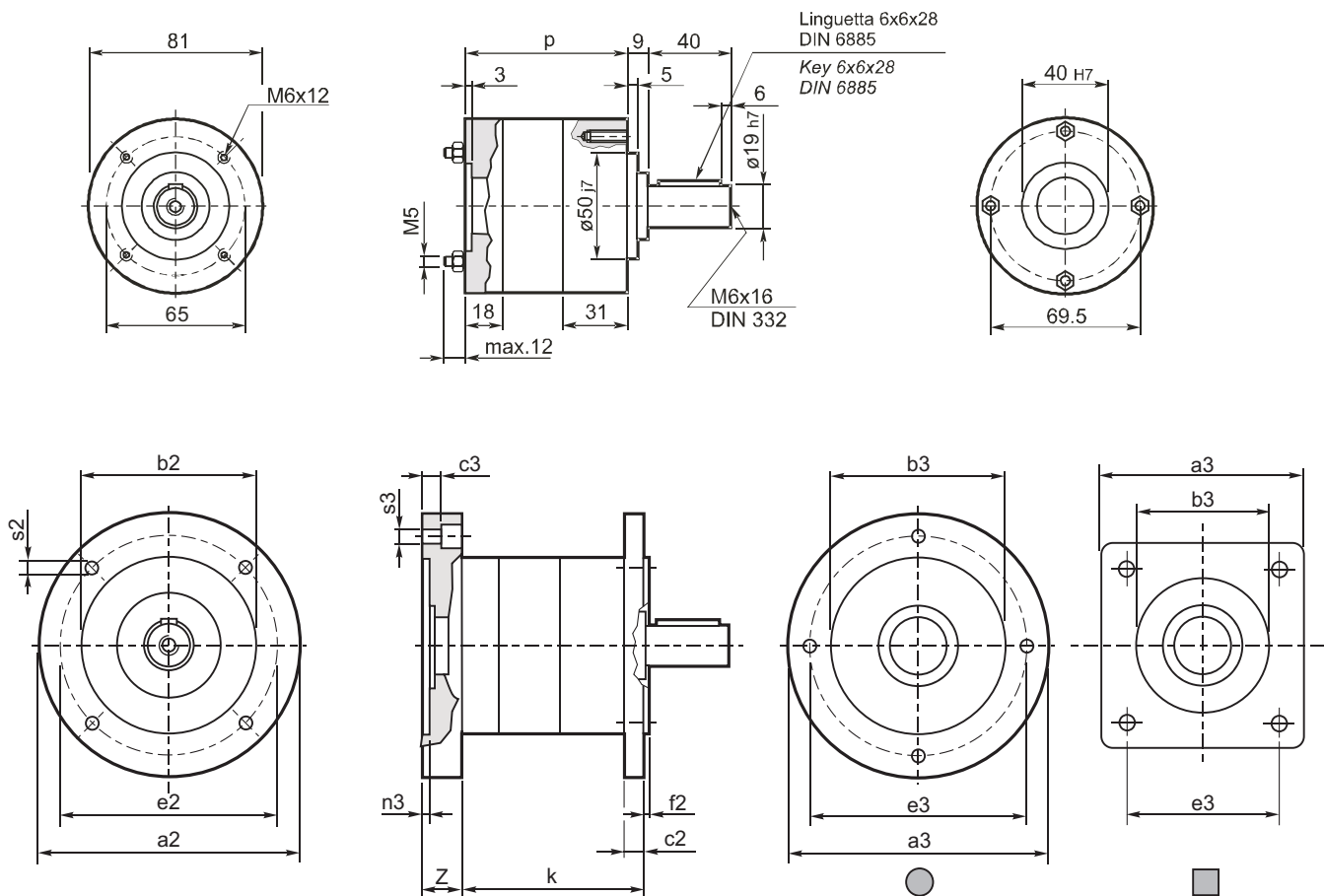

Lunghezza riduttore Gearbox length		N° stadi / No. stages		
		1	2	3
	p	77	99	121
	k	86	108	130

Dimensioni flangia motore Motor flange dimensions		a3	b3	c3	e3	n3	s3	Z
		● C 80	81	50 H7	9	65	3.0	5.3
● C 90	90	60 H7	9	75	3.0	5.3	18	
● C 105	105	70 H7	9	85	3.0	6.3	18	
● C 120	120	80 H7	9	100	3.5	6.3	18	
■ AS 04	100	95 H7	—	81.3	3.5	9	25	
■ AS 12B	85	73.02 H7	—	69.6	2	M5	25	
● AS 22	105	70 H7	15.3	85	3	6.3	25	
● AS 30	81	50 H7	17.3	70	3.5	5.3	24.3	
■ AS 40	80	70 H7	26.3	63.6	4	6.5	34.3	
■ AS 92	85	73.02 H7	—	69.6	2	M5	35	

Dimensioni flangia uscita riduttore Output flange dimensions		a2	b2	c2	e2	f2	s2
		C 90	90	60 j7	9	75	2.5
C 105	105	70 j7	9	85	2.5	M6	
C 120	120	80 j7	9	100	3.0	6.5	

Flange entrata / uscita speciali a richiesta del cliente
Special input / output flanges for specific customer requirements

P105 RIDUTTORI EPICICLOIDALI PLANETARY GEAR UNITS

Dati tecnici

Technical data

Lubrificazione

Grasso (lubrificazione permanente)

Lubrication

Grease (life-time lubrication)

Senso di rotazione

Uguale per albero in ingresso e in uscita

Direction of rotation

Same for input and output shaft

Temperatura di funzionamento consentita

da -30 °C a +140 °C

Operating temperature range

from -30 °C to +140 °C

Velocità nominale in ingresso: 3000 min⁻¹

Input rated speed: 3000 min⁻¹

Simbologia / Symbols

Ns	n° stadi No. stages
in	rapporto nominale nominal ratio
ir	rapporto reale real ratio
M ₂ [Nm]	coppia in uscita in funzionamento continuativo S1 output torque for continuous operation S1
Rd	rendimento dinamico efficiency
R ₂ [N]	massimo carico radiale al centro dell'albero uscita max. radial load at output shaft centre
A ₂ [N]	massimo carico assiale max. axial load
Kg	peso weight

Ns	in	ir	M ₂ [Nm]	Rd	cuscinetto a sfere ball bearing		Kg
					R ₂ [N]	A ₂ [N]	
1	4	3.70	35	0.80	600	120	4.4
	4	4.28					
	5	5.18					
	7	6.75					
2	14	13.73	105	0.75	900	180	6.0
	16	15.88					
	18	18.36					
	19	19.20					
	22	22.20					
	25	25.01					
	27	26.85					
	29	28.93					
	35	34.97					
	46	45.56					
3	51	50.89	195	0.70	1500	300	7.6
	59	58.85					
	68	68.06					
	71	71.16					
	79	78.71					
	93	92.70					
	95	95.17					
	100	99.50					
	107	107.20					
	115	115.07					
	124	123.97					
	130	129.62					
	139	139.13					
150	149.90						
169	168.84						
181	181.24						
195	195.26						
236	236.09						
308	307.54						

Disponibile 4 stadi con rapporti fino a 2076 / Available 4 stages with ratio up to 2076

Istruzioni per il montaggio

Attenersi alle seguenti condizioni di montaggio nel determinare le flange di connessione:

Fitting instructions

Please take note of the following mounting conditions when determining the connecting flanges:

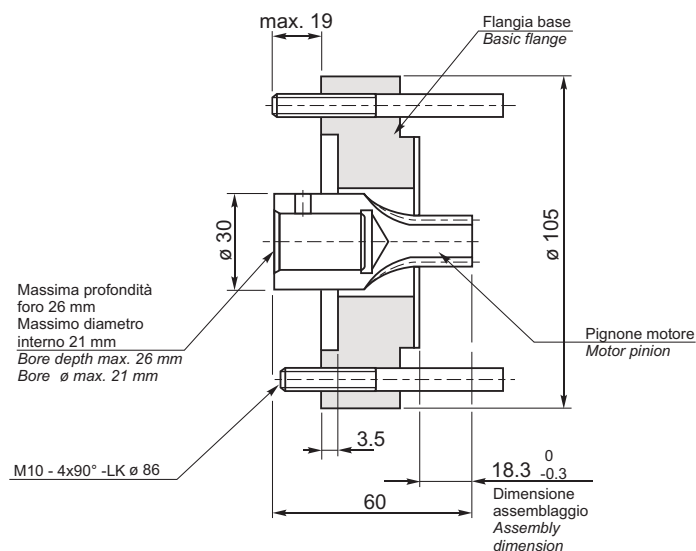

Opzione

Disponibile anche nella versione con serraggio mediante morsetto elastico equilibrato.

Options

Also available with clamp-fixing system.

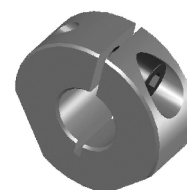

RIDUTTORI EPICICLOIDALI P105

PLANETARY GEAR UNITS

Dimensioni

Dimensions

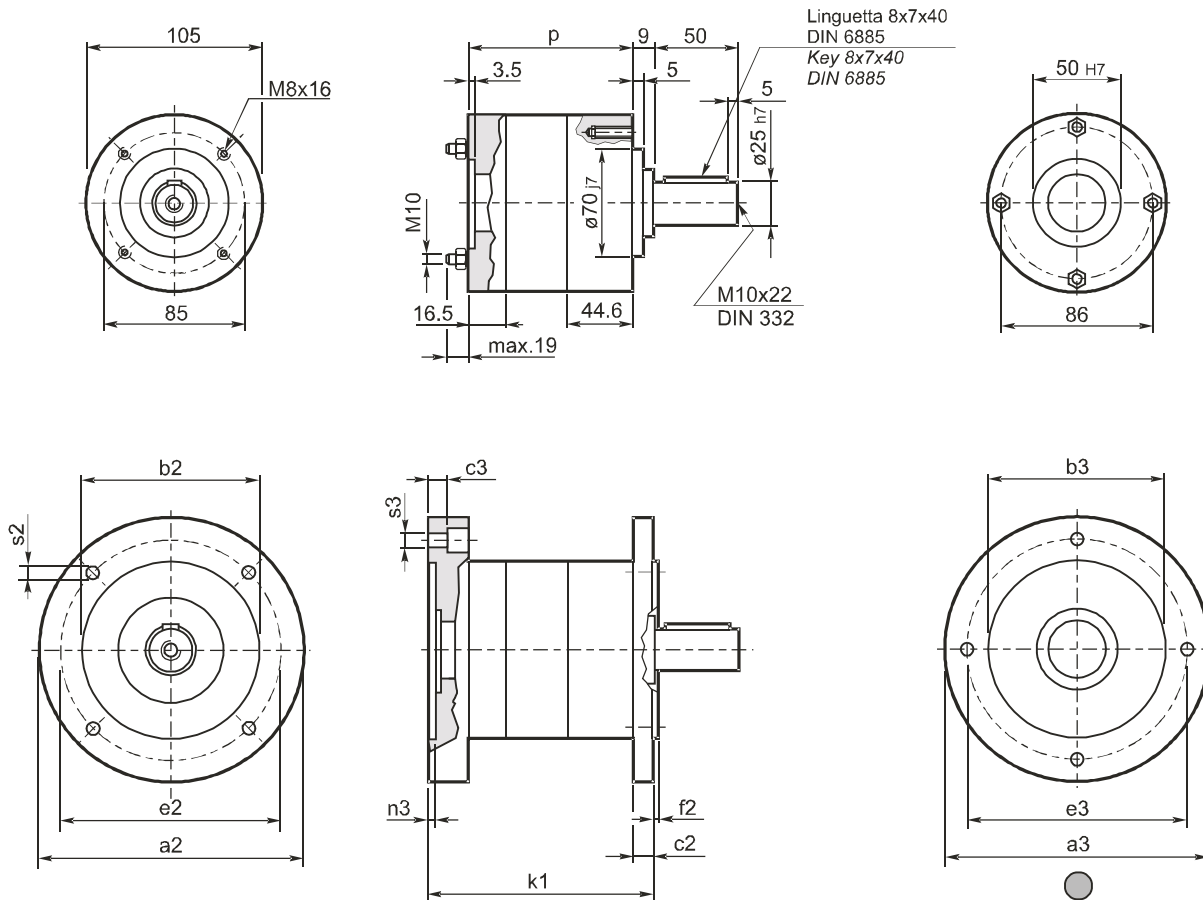

		N° stadi / No. stages		
		1	2	3
Lunghezza riduttore	p	92.9	124	155
Gearbox length	k1	129.2 (71) 139.2 (80)	160.3 (71) 170.3 (80)	191.4 (71) 201.4 (80)

		a3	b3	c3	e3	n3	s3
Dimensioni flangia motore	● C 105	105	70 H7	15	85	3	6.5
	● C 120	120	80 H7	15	100	3.5	6.5
	● C 140	140	95 H7	15	115	3.5	8.5
	● C 160	160	110 H7	15	130	4	8.5

		a2	b2	c2	e2	f2	s2
Dimensioni flangia uscita riduttore	C 120	120	80 j7	12	100	3	M6
	C 140	140	95 j7	12	115	3.5	M8
	C 160	160	110 j7	12	130	3.5	M8

Flange entrata / uscita speciali a richiesta del cliente
Special input / output flanges for specific customer requirements

RIDUTTORI EPICICLOIDALI P120

PLANETARY GEAR UNIT

Dimensioni

Dimensions

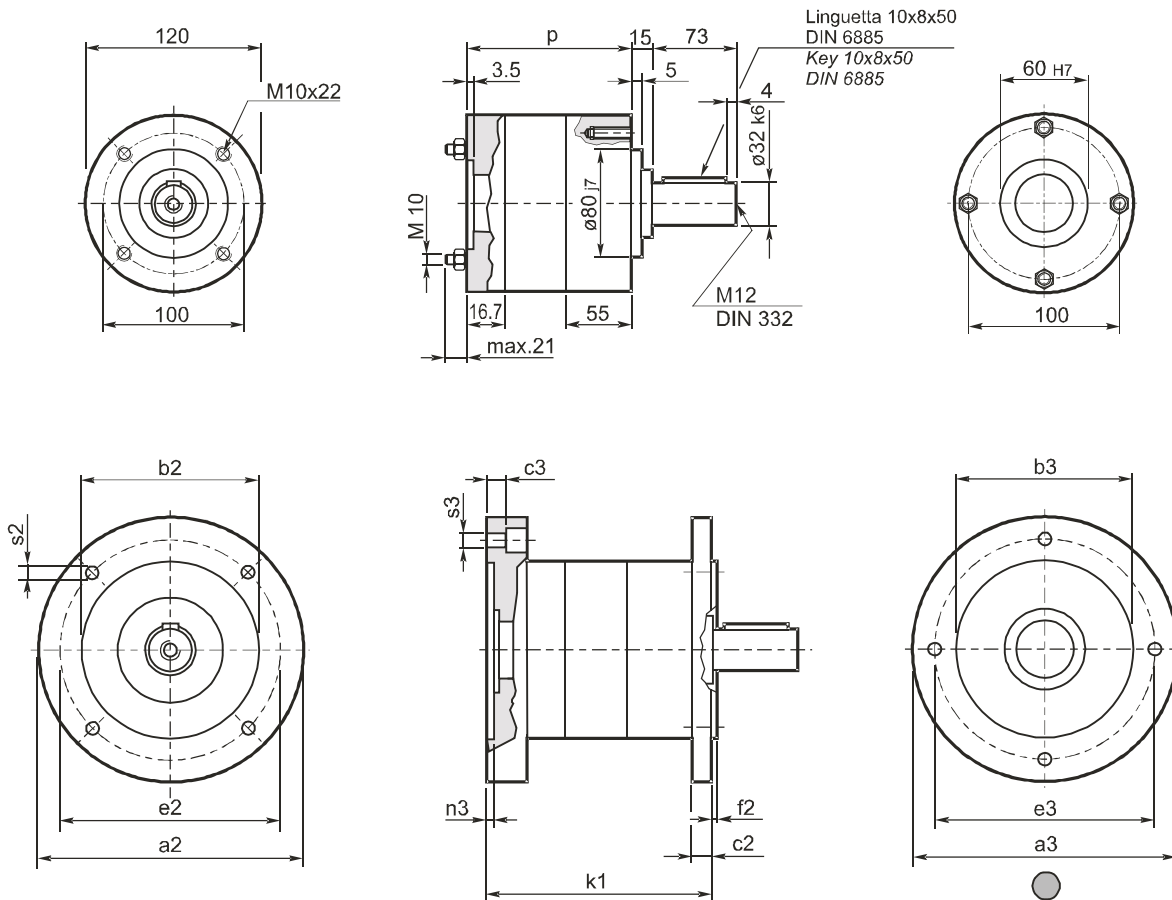

		N° stadi / No. stages		
		1	2	3
Lunghezza riduttore				
Gearbox length	p	106.4	140.6	174.8
	k1	148.9 (71) 158.9 (80)	183.1 (71) 193.1 (80)	217.3 (71) 227.3 (80)

		a3	b3	c3	e3	n3	s3
Dimensioni flangia motore	● C 105	120	70 H7	15	85	3	6.5
	● C 120	120	80 H7	15	100	3.5	6.4
	● C 140	140	95 H7	15	115	3.5	8.5
	● C 160	160	110 H7	15	130	4	8.5

		a2	b2	c2	e2	f2	s2
Dimensioni flangia uscita riduttore	C 140	140	95 j7	15	115	3	M8
	C 160	160	110 j7	15	130	3.5	M8

Flange entrata / uscita speciali a richiesta del cliente
Special input / output flanges for specific customer requirements

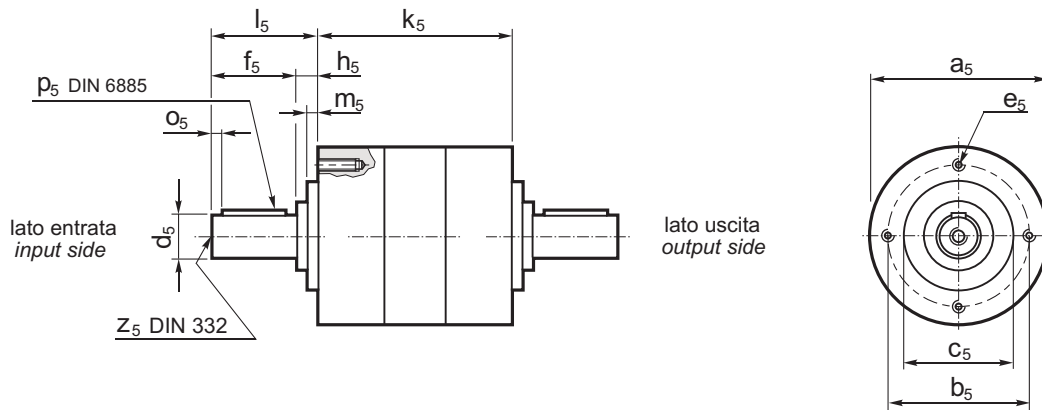

stadi/stages	P 42			P 52			P 62			P 72			P 81			P 105			P 120		
	1	2	3	1	2	3	1	2	3	1	2	3	1	2	3	1	2	3	1	2	3
k₅	61	74	87	71	85	99	69	86	103	83	102	122	90	112	134	106	137	169	132	166	200
a₅	42			52			62			72			81			105			120		
b₅	36			40			52			60			65			85			100		
c₅	25 h9			32 h8			40 j7			45 j7			50 j7			70 j7			80 j7		
d₅	6 h7			10 h7			12 h7			14 h7			16 h7			19 h7			28 h7		
e₅	M4 x 10 (4 x 90°)			M5 x 10 (4 x 90°)			M5 x 10 (4 x 90°)			M5 x 10 (4 x 90°)			M6 x 12 (4 x 90°)			M8 x 16 (4 x 90°)			M10 x 22 (4 x 90°)		
f₅	22.2			20			30			30			40			40			58		
h₅	2.8			5			9			9			9			9			15		
l₅	25			25			39			39			49			49			73		
m₅	2			3			5			5			5			5			5		
o₅	3			2			5			5.5			5			6			4		
p₅	A 2 x 2 x 16			A 3 x 3 x 16			A 4 x 4 x 20			A5x5x22			A 5 x 5 x 30			A 6 x 6 x 28			A 10 x 8 x 50		
z₅	—			M3 x 9			M4 x 10			M5x12.5			M5 x 12.5			M6 x 16			M10 x 22		

Carico albero basato sul centro dell'albero

referito a $n_1=3000 \text{ min}^{-1}$

Shaft load based on shaft centre and $n_1=3000 \text{ min}^{-1}$

		P 42	P 52	P 62	P 72	P 81	P 105	P 120
Radiale Radial	[N]	70	110	120	160	200	240	300
Assiale Axial	[N]	40	50	60	80	100	125	150